

**COMPACT  
POWER SUPPLY**

**Model JQE 55-20 (M) E**

**Serial No. 74.87306**

# **INSTRUCTION MANUAL**

The KEPCO equipment described in this instruction manual is of proprietary design, and is licensed under the United States patent rights of Forbro Design Corp.

The contents of this instruction manual are copyrighted. Reproduction of any part may only be made with the specific written permission of KEPCO, Inc. Data subject to change without notice.

**KEPCO®**

© KEPCO, Inc. 1970

KEPCO, INC. • 131-38 SANFORD AVENUE • FLUSHING, N.Y. 11352 • (212) 461-7000 • TWX #710-582-2631 • Telex: 12-6055 • Cable: KEPCOPOWER NEWYORK

# TABLE OF CONTENTS

PARAGRAPH		PAGE
<b>SECTION I – INTRODUCTION</b>		
1-1	Scope of Manual	1-1
1-3	General Description	1-1
1-9	Accessories	1-1
1-10	Specifications, General	1-1
1-11	Specifications, Electrical	1-2
1-12	Specifications, Performance	1-3
1-13	Specifications, Physical	1-3
<b>SECTION II – INSTALLATION</b>		
2-1	Unpacking and Inspection	2-1
2-3	Terminations	2-1
2-4	AC Input Requirements	2-2
2-6	Cooling	2-2
2-8	Preliminary Check-Out	2-2
2-10	Installation	2-3
2-12	Grounding	2-3
<b>SECTION III – OPERATION</b>		
3-1	Load Connection without Error Sensing	3-1
3-2	Load Connection with Error Sensing	3-1
3-3	Kepeco Power Supply Circuit with Comparison Bridge	3-2
3-4	Connections for Precision Programming Ratio Adjustment	3-4
3-5	Establishing Programming Linearity	3-4
3-6	Remote Resistance Programming	3-6
3-7	Remote Conductance Programming	3-7
3-8	The Power Supply in the Operational Amplifier Mode	3-8
3-9	Constant Current Operating Mode	3-9
3-10	Automatic Series Connection	3-12
3-11	Master-Slave Series Connection	3-13
3-12	Parallel Operation	3-15
3-13	Basic Parallel Connection	3-16
3-14	Master-Slave Parallel Connection	3-17/3-18
<b>SECTION IV – THEORY OF OPERATION</b>		
4-1	Simplified Diagram Discussion	4-1
4-5	Circuit Description	4-2
<b>SECTION V – MAINTENANCE</b>		
5-1	General	5-1
5-3	Disassembly	5-1
5-4	Internal Adjustment Procedures	5-2
5-8	Trouble Shooting	5-2
5-13	Power Supply Measurements	5-3
<b>SECTION VI – ELECTRICAL PARTS LIST AND DIAGRAMS</b>		
6-1	General	6-1/6-2
6-3	Ordering Information	6-1/6-2

## LIST OF ILLUSTRATIONS

FIGURE		PAGE
1-1	Kepeco Full-Rack JQE Power Supply, Front View (Typical) . . . . .	-iii-
1-2	Kepeco Full-Rack JQE Power Supply, Rear View (Typical) . . . . .	-iv-
1-3	Mechanical Outline Drawing . . . . .	1-4
2-1	Location of Internal Adjustments . . . . .	2-1
2-2	Conversion to 230V AC Operation . . . . .	2-2
2-3	Controls and Terminations, JQE Full-Rack Models, Front . . . . .	2-4
2-4	Rear Terminations, JQE Full-Rack Models . . . . .	2-5
2-5	Rack Installation . . . . .	2-6
3-1	Load Connection without Error Sensing . . . . .	3-1
3-2	Load Connection with Error Sensing . . . . .	3-1
3-3	Kepeco Power Supply Circuit with Comparison Bridge . . . . .	3-2
3-4	Connections for Precision Programming Ratio Adjustment . . . . .	3-4
3-5	Establishing Programming Linearity . . . . .	3-4
3-6	Remote Resistance Programming . . . . .	3-6
3-7	Remote Conductance Programming . . . . .	3-7
3-8	The Power Supply in the Operational Amplifier Mode . . . . .	3-8
3-9	Constant Current Operating Mode . . . . .	3-10
3-10	Automatic Series Connection . . . . .	3-12
3-11	Master-Slave Series Connection . . . . .	3-13
3-12	Parallel Operation . . . . .	3-14
3-13	Basic Parallel Connection . . . . .	3-15
3-14	Master-Slave Parallel Connection . . . . .	3-16
4-1	Simplified Schematic with Rear Connection Detail . . . . .	4-1
5-1	Disassembly, JQE Full-Rack Models . . . . .	5-1
5-2	Connections for Power Supply Measurements . . . . .	5-4
6-1	Component Location, Chassis and Auxiliary Boards . . . . .	6-17
6-2	Component Location, Amplifier and VP Assembly . . . . .	6-18
6-3	Main Schematic . . . . .	6-19/6-20

## LIST OF TABLES

TABLE		PAGE
1-1	JQE (Full-Rack) Group, Specifications-General . . . . .	1-2
1-2	JQE (Full-Rack) Group, Specifications-Electrical . . . . .	1-3
2-1	Internal Adjustments . . . . .	2-1
2-2	Controls and Terminations, Full-Rack JQE Models, Front . . . . .	2-4
2-3	Rear Terminations, Full-Rack JQE Models . . . . .	2-5

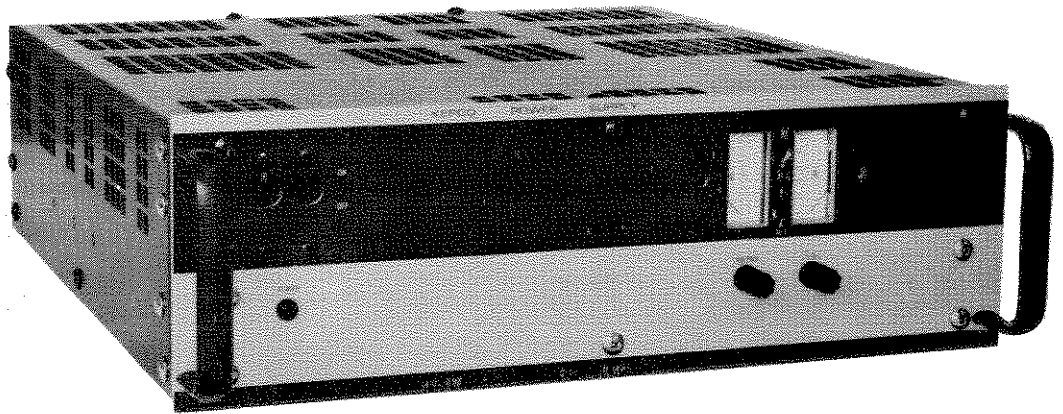

FIG. 1-1 KEPCO FULL-RACK JQE POWER  
SUPPLY, FRONT VIEW (TYPICAL)

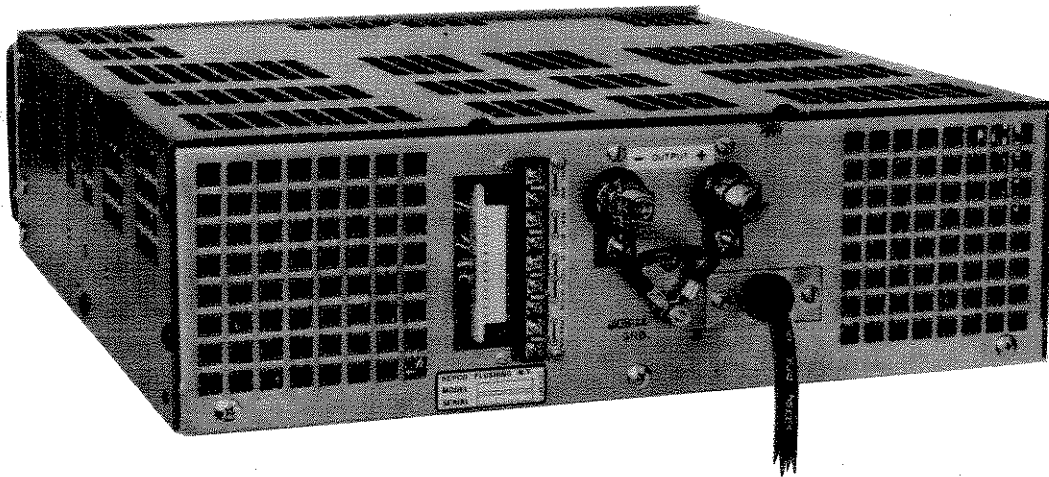

FIG. 1-2 KEPCO FULL-RACK JQE POWER SUPPLY, REAR VIEW (TYPICAL)

## SECTION I – INTRODUCTION

### 1-1 SCOPE OF MANUAL

- 1-2 This manual contains instructions for the installation, operation and maintenance of the Kepco JOE "FULL-RACK" Series of Power Supplies.

### 1-3 GENERAL DESCRIPTION

- 1-4 Kepco Series JOE Power Supplies are general purpose, precision regulated voltage sources in the "FULL-RACK" configuration. JOE Power Supplies feature full range voltage control and current limit adjustment by means of multi-turn front panel controls. Dual range meters monitor output voltage and load current. JOE Power Supplies have linear, full-dissipation series-regulators (NPN) driven by an integrated circuit operational amplifier. A sharp current-limit circuit renders the power supply completely short-circuit proof. JOE Power Supplies may be readily converted to provide constant current by the addition of an external sensing resistor and a "current control". The output of the JOE Power Supply is completely programmable. All necessary connections are available on terminals at the rear barrier-strip.
- 1-5 The compact design of the Kepco JOE "FULL-RACK" Series was made possible by a unique heatsink design of exceptional efficiency in combination with highly reliable low-noise fans. JOE Power Supplies feature all-silicon design with conservatively rated components for added reliability.
- 1-6 JOE Power Supplies are identical in their mechanical dimensions (Refer to FIG. 1-3; "Mechanical Outline Drawing") and in their electrical specifications, except as noted in TABLE 1-1.
- 1-7 OPTIONS. Optional features of Kepco Power Supplies are indicated by a letter following the model designation:
- JOE Power Supplies with suffix "E" are equipped with an "E<sub>0</sub> Null" adjustment, which allows exact zero calibration for precision programming applications.
  - JOE Power Supplies with suffix "HS" are optimized for high speed programming. For these models, a special addendum containing all supplementary specifications is provided in the appendix of the manual. The "E<sub>0</sub> Null" ("E") option is automatically included with the "HS" option.
  - JOE Power Supplies with suffix "M" are equipped with two dual range panel meters which permit simultaneous monitoring of the output voltage and output current. Meter range-switches allow for full scale reading of either 10% or 100% of the voltage and current outputs.
  - JOE Power Supplies with suffix "T" have special references which improve the temperature coefficient of the supply (See paragraph 1-11 for specifications).
  - JOE Power Supplies with suffix "VP" are equipped with an overvoltage protector. This electrical "crowbar" shorts the output through a silicon controlled rectifier (SCR) if the output voltage exceeds a preadjustable limit on the protector (See paragraph 1-12 for specifications).
- 1-8 The main chassis frame of the power supply is constructed from cold-rolled steel, as is the perforated wrap-around cover. Front panel material is aluminum (Refer to FIG. 1-3 for finish).

### 1-9 ACCESSORIES

- a) Mounting Brackets for rack-installation (supplied, see FIG. 2-5 for installation instruction).

### 1-10 SPECIFICATIONS, GENERAL

- AC INPUT: 105 to 125V AC or 210 to 250V AC (selectable, refer to SECTION II), 50 to 65 Hz,\* single phase. Refer to the table of general specifications (TABLE 1-1) for the AC input current for each model.
- OPERATING TEMPERATURE RANGE: (-)20°C to (+)71°C (without derating of the output).
- STORAGE TEMPERATURE: -50°C to (+)85°C.
- COOLING: High efficiency, single bearing fans, (permanently lubricated) with special low noise non-metal blade.
- ISOLATION: A maximum of 500 volts (DC or p-p) can be connected between chassis and either output terminal.

\*Consult factory for operation above 65 Hz.

## 1-11 SPECIFICATIONS, ELECTRICAL

a) Refer to TABLE 1-1 and 1-2.

MODEL	DC OUTPUT RANGE		OUTPUT IMPEDANCE (OHMS + $\mu$ H)			APPROXIMATE MAXIMUM AC INPUT CURRENT Amps @ 125V AC
	VOLTS	AMPERES	DC-100 Hz	0.1-1 kHz	1 kHz-100 kHz	
JQE 6-90(M)	0-6	0-90	$3.5 \times 10^{-6}$	0.001	$0.005 + 1$	15.7
JQE 15-50(M)	0-15	0-50	$15.0 \times 10^{-6}$	0.001	$0.005 + 1$	16.6
JQE 25-40(M)	0-25	0-40	$31.0 \times 10^{-6}$	0.001	$0.005 + 0.5$	21.0
JQE 36-30(M)	0-36	0-30	$70.0 \times 10^{-6}$	0.001	$0.005 + 0.5$	19.0
JQE 55-20(M)	0-55	0-20	$1.38 \times 10^{-4}$	0.01	$0.02 + 1$	18.0
JQE 75-15(M)	0-75	0-15	$2.50 \times 10^{-4}$	0.005	$0.01 + 1$	18.0
JQE 100-10(M)	0-100	0-10	$6.2 \times 10^{-4}$	0.005	$0.02 + 1$	17.0
JQE 150-7(M)	0-150	0-7	$1.1 \times 10^{-3}$	0.01	$0.05 + 2$	18.0

NOTE: Specifications for unmetered models (without suffix "M") are identical.

TABLE 1-1 DC OUTPUT AND AC INPUT SPECIFICATIONS.

**NOTE:** With the introduction of the 1970 Catalog (B-703), Kepco has adopted new technical terms recommended by the International Electrotechnical Commission (IEC). These terms replace or supplement previously used expressions, mainly to avoid difficulties in translation and prevent erroneous interpretations at home and abroad.

As a beginning, Kepco will discontinue the use of the specifications entitled "Line Regulation" and "Load Regulation" because of the long standing (and misleading) connotation that a power supply regulates the line or the load. Instead, Kepco will follow the recommendation of the IEC and speak of the "Output Effects, caused by changes in the Influence Quantities." The "Output Effects" are specified as before, either as a percentage change referred to the maximum specified output voltage ( $E_O$ ) or current ( $I_O$ ) or as an absolute change ( $\Delta E_O$ ,  $\Delta I_O$ ) directly in millivolts or milliamperes or both. The "Influence Quantities" are the "Source Variations" (formerly a-c line variations), the changes in load, temperature or time as previously specified. The illustration below will clarify the use of the new terminology.

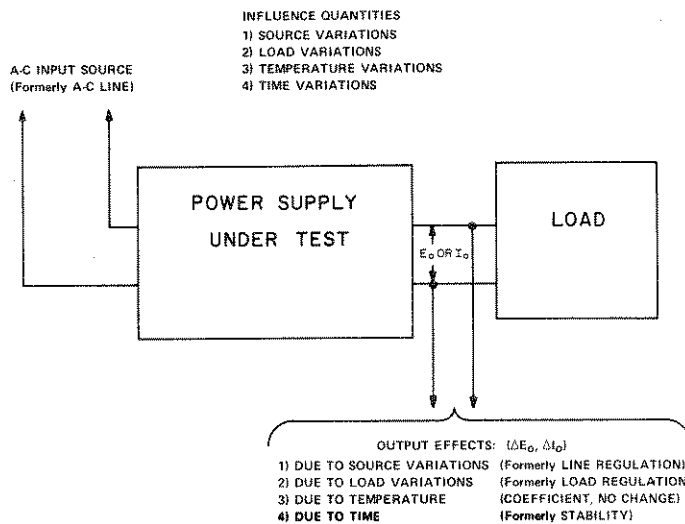

- b) VOLTAGE RECOVERY TIME: (for step load current),  $< 50 \mu\text{sec}$ .
- c) OVERSHOOT: No output voltage overshoot from turn-on, turn-off, or power failure for output settings above 25% of maximum rated output voltage. Below 25% output voltage overshoot is a function of load current and is negligible for loads in excess of 10% of the maximum rated load current.

SPECIFICATION	OUTPUT EFFECTS	OUTPUT EFFECTS	VOLTAGE AMPLIFIER OFFSETS****		VOLTAGE REFERENCE (Internal)****
	VOLTAGE MODE	CURRENT MODE***	OFFSET VOLTAGE $\Delta E_{iO}$	OFFSET CURRENT $\Delta I_{iO}$	
OUTPUT RANGE:	0–100% $E_O$ max.	1 mA–100% $I_O$ max.			Fixed 6.2V $\pm 5\%$
SOURCE: 105–125/210–250V a-c	<0.0005%	<0.005%	<10 $\mu V$	<2 nA	0.0001%
LOAD: No load – full load	<0.005% or 0.2 mV*	<0.01%	<200 $\mu V$	<5 nA	-----
TIME: 8-hours (drift)	<0.01% or 1 mV*	<0.02	<20 $\mu V$	<2 nA	0.005%
TEMPERATURE: Per °C	<0.01%**	<0.02**	<20 $\mu V$	<5 nA	0.005%
RIPPLE: (rms)	<0.2 mV	<0.02% of $I_O$ max.	-----	-----	-----

\*NOTE: Whichever is greater.

\*\*NOTE: Models with suffix "T" have 0.005% and 0.01% per °C Temperature Coefficients in the Voltage and Current Mode respectively.

\*\*\*NOTE: Current Mode Output Effects ( $\Delta I_O$ ) are measured across the external sensing resistor. This resistor must be a high quality, wirewound unit, with a wattage at least 10 times the actual power dissipated, have a Temperature Coefficient of 20 parts per million or better and drop a sample voltage of 1.0 volt at the measuring current. A resistor built as a 4-terminal network is recommended. Current control is exercised with an external 20 PPM feedback resistor.

\*\*\*\*Offsets and the reference contribute to output effect  $\Delta E_O$  by the equation  $\Delta E_O = \pm \Delta E_{ref} (R_f/R_i) \pm \Delta E_{iO} (1 + R_f/R_i) \pm \Delta I_{iO} (R_f)$  where  $R_f$  is the feedback resistor and  $R_i$  is the input resistor from the signal reference. Use the offsets to calculate output effects when external input/feedback elements are substituted for the internal reference and voltage control in special applications.

TABLE 1-2 ELECTRICAL SPECIFICATIONS

### 1-12 SPECIFICATIONS, PERFORMANCE

- VOLTAGE CONTROL\*: 10 turn precision rheostat at the front panel, resolution: 0.05% of  $E_O$  max. Controls the output voltage from zero to  $E_O$  max.
- CURRENT LIMIT CONTROL\*: 10 turn vernier control at the front panel permits adjustment of the current limit from 10% to 105% of the maximum rated output current ( $I_O$ ).
- REMOTE ERROR SENSING: Rear barrier-strip terminals provide for connection of the error sensing leads directly at the load, thus compensating for losses due to load current voltage drops. Up to 0.5V per output lead can be compensated.
- REMOTE PROGRAMMING: Rear barrier terminals provide for remote control of the power supply by resistance (control loop uses 1 mA with a Programming Ratio of 1000 ohms per volt), or by external control voltage.
- SERIES/PARALLEL: Series operation of JQE Power Supplies is possible up to the rated isolation voltage. Parallel operation using "Automatic Parallel" or "Slave-Master" parallel connections may be performed.
- OVERVOLTAGE PROTECTOR (MODELS WITH SUFFIX "VP")  
Electronic "Crowbar" circuit shorts the output through a silicon controlled rectifier (SCR) as soon as the power supply output voltage reaches a preset limit on the "VP" device. The over-voltage protector device (VP) has the following specifications:
  - RANGE: 3V DC – 175V DC (adjustable).
  - TRIGGERING TIME: 5 to 10 microseconds, adjustable by means of a delay-control.
  - THRESHOLD: Overvoltage device may be set to within 5% or 0.25 volts of the power supply's output voltage (whichever is greater).

\*Knob controlled on all metered models (suffix "M"), locking type screw-driver controls on unmetered models.

### 1-13 SPECIFICATIONS, PHYSICAL

- DIMENSIONS: Refer to "Mechanical Outline Drawing", (FIG 1-3).
- TERMINATIONS: Refer to "Mechanical Outline Drawing" (FIG. 1-3) and Section II of this manual.
- FINISH:
  - CHASSIS: cadmium plated, cronak wash.
  - PANEL (on models with suffix "M" only): Light gray, Color #26440, Federal Standard 595.
  - CASE: Charcoal gray texture.
- METERS (on model with suffix "M" only): Two dual range (100% and 10% of  $E_O$  max. and  $I_O$  max.), 2 inch recessed panel meters, accuracy 3% of full scale reading, for output voltage and output current monitoring.
- MOUNTING: Refer to "Mechanical Outline Drawing" (FIG. 1-3). Four (4) aluminum feet are provided for bench operation of the supply. Feet are removable for rack-mounting. Adaptor brackets for mounting the supply into a standard (19 inch) rack are supplied. Refer to FIG 2-5 for installation instructions.



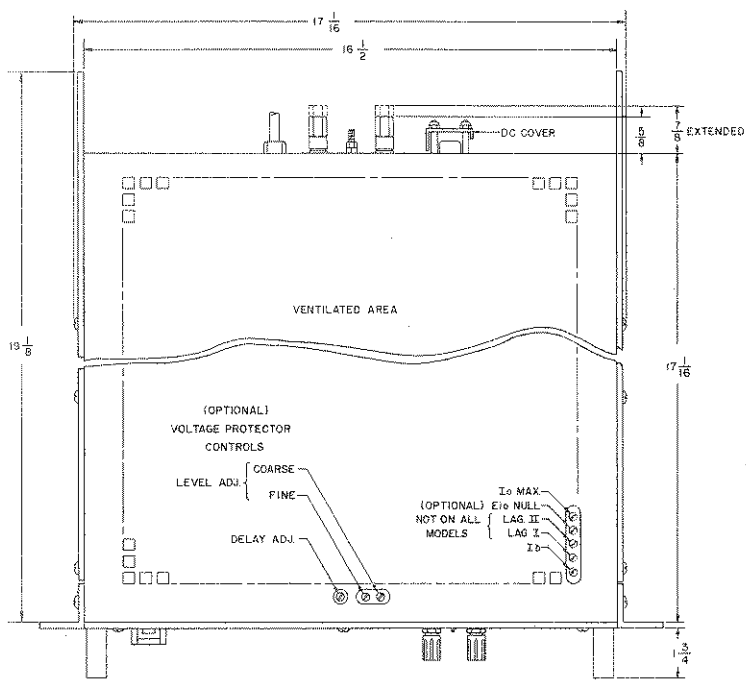

**REAR OUTPUT TERMINAL FUNCTIONS:**

1. (+) OUTPUT MONITOR
2. (-) SENSING
3. (-) OUTPUT MONITOR
4. (-) SENSING
5. Rvc
6. NULL JUNCTION
7. Rr
8. Er
9. Rr

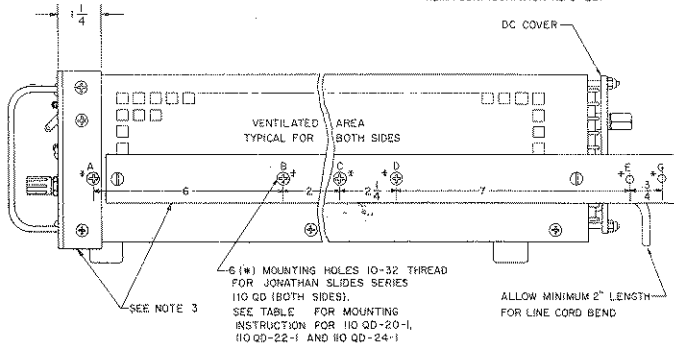
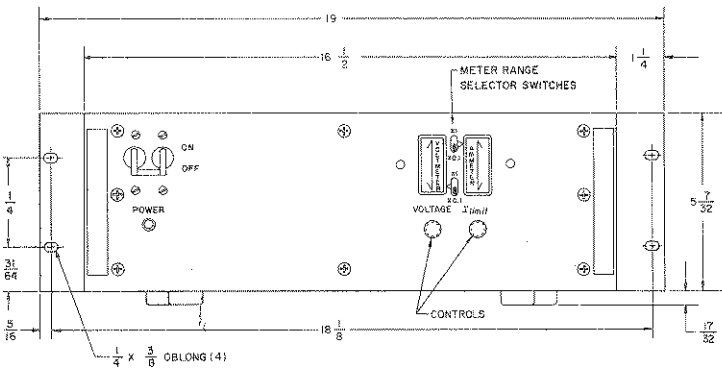
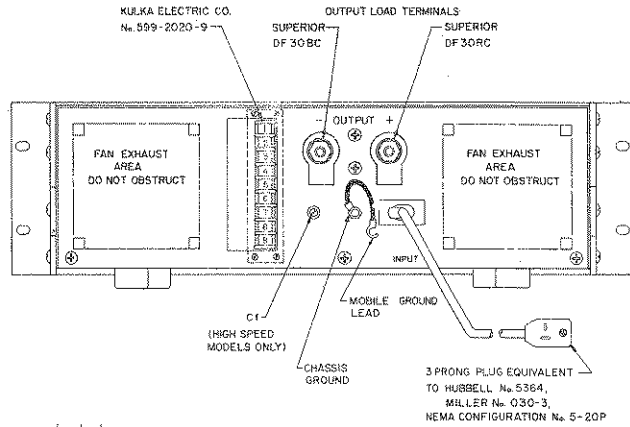

MOUNTING TABLE		USE MOUNTING HOLES			
SLIDE TYPE	A	B	D	G	
110QD-20-1	A	B	D	G	
110QD-22-1	A	C	D	G	
110QD-24-1	A	C	E	NOT USED	

- NOTES: 1. THIS DRAWING IS USED FOR THE MODELS: JQE55-20 (M)(VP)(E)(T)(HS), JOE100-10 (M)(VP)(E)(T)(HS), JOE75-15 (M)(VP)(E)(T)(HS), JOE150-7 (M)(VP)(E)(T)(HS), JOE75-13 (M)(VP)(E)(T)(HS) AND JOE55-18 (M)(VP)(E)(T)(HS).
2. MATERIAL: A) CHASSIS: #11 GA. C.R.S.  
B) FRONT PANEL: 3/16 THICK ALUMINUM  
C) COVER: 3/32 THICK ALUMINUM
  3. FINISH: A) CHASSIS: CADMIUM PLATE WITH A YELLOW CHROMATE WASH  
B) FRONT PANEL: LIGHT GRAY PER FEDERAL STD. 595, COLOR # 26440  
C) COVER: CHARCOAL GRAY VINYL TEXTURE.
  4. FIXED ANGLE BRACKETS AND CHASSIS SLIDES SUPPORT BAR (BOTH SIDES) USED FOR RACK OR CABINET INSTALLATION. CAN BE REMOVED FOR BENCH OPERATION.
  5. (4) ALUMINUM FEET TO BE REMOVED FOR RACK OR CABINET MOUNTING

CAUTION  
WHEN INSTALLING MODEL INTO RACK OR CABINET, THE MODEL MUST BE SUPPORTED EITHER BY FIXED ANGLE BRACKETS (SEE NOTE # 3) AND CHASSIS SLIDE (SEE MOUNTING TABLE) OR BY FIXED ANGLE BRACKETS AND RIGID PLATFORMS MOUNTED IN THE RACK OR CABINET  
NOTE: CHASSIS SLIDES AND RIGID PLATFORM ARE NOT SUPPLIED.

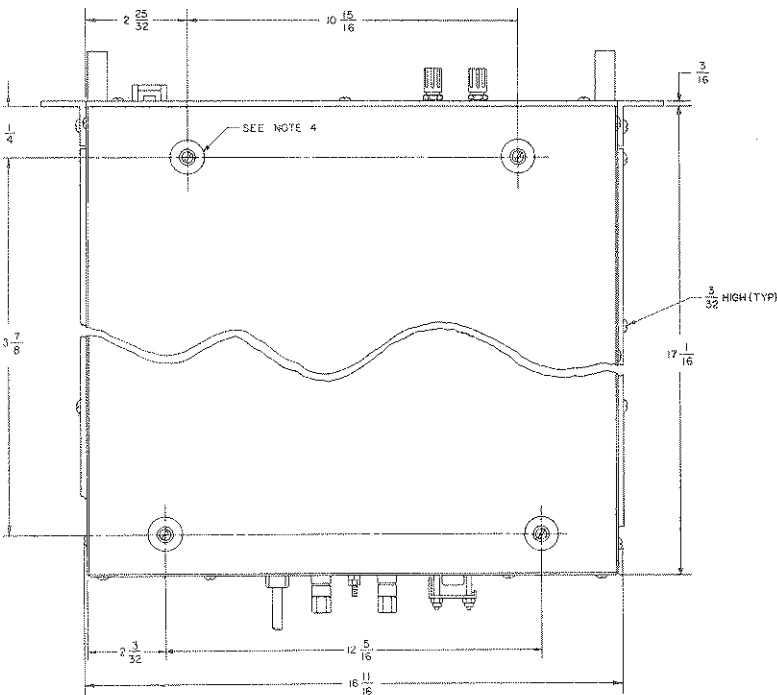

**FIG. 13 MECHANICAL OUTLINE DRAWING**

## SECTION II – INSTALLATION

### 2-1 UNPACKING AND INSPECTION

2-2 This instrument has been thoroughly inspected and tested prior to packing and is ready for operation. After careful unpacking, inspect for shipping damage before attempting to operate. Perform the preliminary operational check as outlined in paragraph 2-8 below. If any indication of damage is found, file an immediate claim with the responsible transport service.

### 2-3 TERMINATIONS

- a) FRONT PANEL: Refer to FIG. 2-3 and TABLE 2-2.
- b) REAR: Refer to FIG. 2-4 and TABLE 2-3.
- c) INTERNAL ADJUSTMENTS AND CALIBRATIONS: Refer to FIG. 2-1 and TABLE 2-1.

REFERENCE DESIGNATION	CONTROL	PURPOSE	ADJUSTMENT PROCEDURE
C403**	Delay Adjust	Adjust Delay Time of VP	
R4	$I_b$ Adjust	Control Current Calibration	par. 3-16
R14***	$E_{i0}$ Null Adjust	Output Voltage Precision zero	par. 3-16
R16*	Lag Adjust	AC Stability adjustment	par. 5-7
R19	$I_o$ Max. Adjust	Current Limit Control Calibration	par. 5-6
R26****	Ammeter Zero Adj.	Set Ammeter "Zero"	par. 4-6
R36*	Lag Adjust	AC Stability Adjustment	par. 5-7
R414**	Overvoltage Level Adjust (FINE)	Adjusts Protector Threshold	par. 3-6
R415**	Overvoltage Level Adjust (COARSE)	Adjusts Protector Threshold	par. 3-6

\*Not used on all models.

\*\*\*Used on models with suffix "E" only.

\*\*Used on models with suffix "VP" only.

\*\*\*\*Used on Model JQE 6-90M only.

TABLE 2-1 INTERNAL ADJUSTMENTS AND CALIBRATION

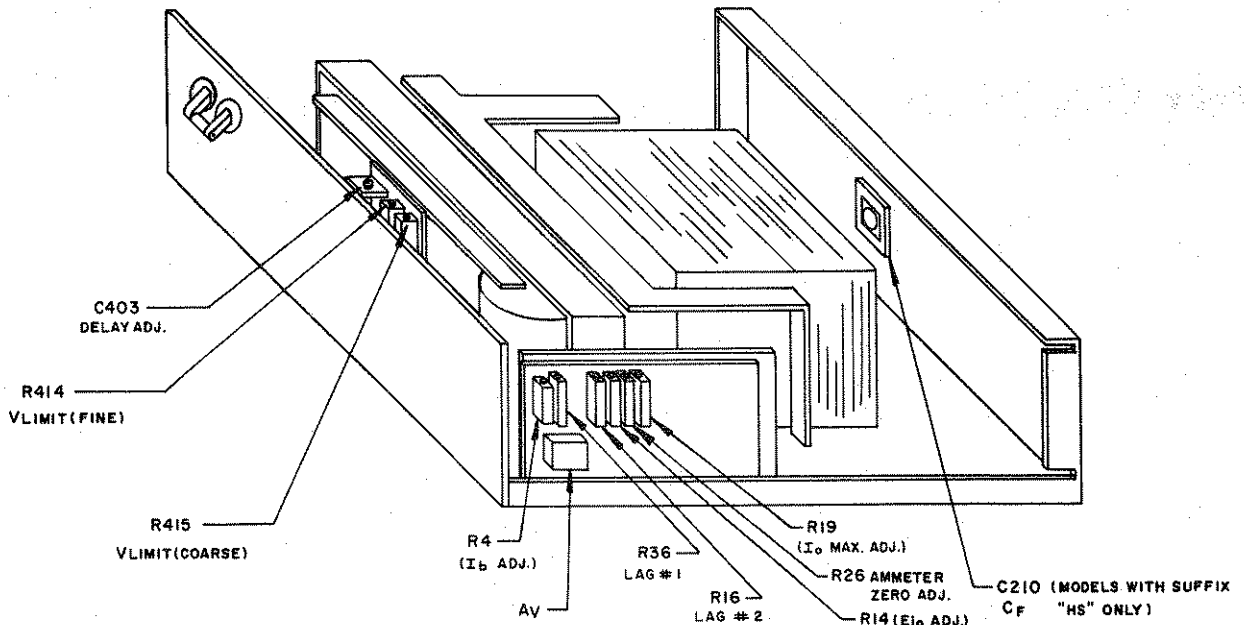

NOTE: All adjustments accessible through top of wrap-around cover.

FIG. 2-1 LOCATION OF INTERNAL ADJUSTMENTS

## 2-4 AC INPUT REQUIREMENTS

- 2-5 This power supply is normally supplied for operation on a single phase, nominal 115V AC line. For conversion to 230V AC line operation, refer to FIG. 2-2. Remove the two links between transformer terminals (1)-(2) and (3)-(4). Reconnect one (1) link between terminals (2) and (3). DO NOT CHANGE ANY OTHER WIRING ON THE TRANSFORMER.

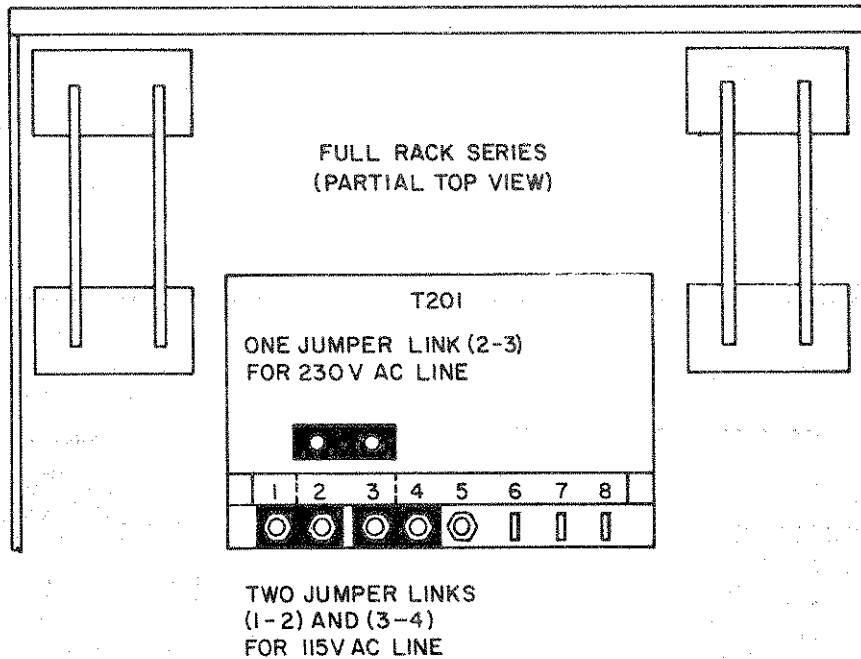

FIG. 2-2 CONVERSION TO 230V AC NOMINAL LINE OPERATION

## 2-6 COOLING

- 2-7 The power transistors and rectifiers in this power supply are maintained within their operating temperature range by means of high efficiency heat-sink assemblies, cooled by internal fans. SIDE PANEL OPENINGS AND THE TOP OF THE CASE MUST BE KEPT CLEAR FROM OBSTRUCTIONS TO INSURE PROPER AIR CIRCULATION. Periodic cleaning of the interior of the power supply is recommended. If the power supply is rack mounted, or installed into confined spaces, care must be taken that the ambient temperature does not rise above the limit specified (71°C).

## 2-8 PRELIMINARY CHECK-OUT

- 2-9 A simple operating check after unpacking and before permanent installation is advisable, to ascertain whether the power supply has suffered damage resulting from shipment. Please refer to FIG. 2-3 for the location of the operating controls and output terminals.
- Connect power supply to 115V AC line or refer to paragraph 2-4 for 230V AC operation if required.
  - If power supply is unmetred, connect a suitable DC voltmeter to the output terminals.
  - Turn CURRENT LIMIT CONTROL fully clockwise. Turn VOLTAGE CONTROL fully counterclockwise. Turn V-LIMIT fully clockwise.
  - Turn AC POWER SWITCH "on". The AC PILOT LIGHT (metred models only) should be energized. Slowly turn VOLTAGE CONTROL clockwise and observe the gradual increase of the output voltage. Turn counterclockwise again.

- e) (MODELS WITH SUFFIX "VP" ONLY). Adjust output voltage to approximately 1/4 of its maximum rated value. Turn V-LIMIT control slowly counterclockwise, until output voltage goes suddenly to zero and the AC POWER SWITCH/CIRCUIT BREAKER trips. Leave AC power "off".

**CAUTION**

CONNECT SHORT CIRCUIT (OR LOAD) TO THE HEAVY DUTY OUTPUT TERMINALS, NOT TO THE BARRIER-STRIP TERMINALS. BARRIER-STRIP TERMINALS ARE FOR VOLTAGE MONITORING AND PROGRAMMING CONNECTIONS ONLY.

- f) (MODELS WITH FRONT PANEL METERS ONLY)  
Place a short circuit across the output. Turn CURRENT LIMIT CONTROL counterclockwise. Turn AC POWER SWITCH/CIRCUIT BREAKER "on". Slowly turn CURRENT LIMIT CONTROL clockwise and observe the gradual increase in output current on the panel AMMETER. The output current should smoothly increase from below 10% to 105% of the maximum rated output current, as the CURRENT LIMIT CONTROL is varied between its limits. Turn AC power "off". This concludes the preliminary check-out.
- g) (MODELS WITHOUT METERS)  
Place a short circuit, consisting of a suitable ammeter, across the output terminals of the unit. Turn CURRENT LIMIT CONTROL fully counterclockwise. Turn AC POWER SWITCH/CIRCUIT BREAKER "on". Slowly turn CURRENT LIMIT CONTROL clockwise, observing the ammeter scale. The output current should smoothly vary from below 10% to 105% of maximum rated output current as the CURRENT LIMIT CONTROL is adjusted from its maximum counterclockwise position. Turn AC power "off". This concludes the preliminary check-out.

## 2-10 INSTALLATION

- 2-11 a) (METERED MODELS)  
The JOE Power Supply may be used as a bench operated instrument or, with the assistance of the mounting brackets, it may be installed in any standard 19 inch rack. Please refer to paragraph 2-6 ("COOLING") if the supply is mounted into a multiple rack installation. Instructions for rack installation are provided (See FIG. 2-5).
- b) (UNMETERED MODELS)  
The JOE Power Supply is designed for chassis mounting directly into existing installations. For mounting hole dimensions and lay-out see FIG. 1-3 ("Mechanical Outline Drawing"). If the unit must be mounted into confined spaces, refer to paragraph 2-6 ("COOLING").

## 2-12 GROUNDING

- a) AC GROUND. The power supply is equipped with a 3-wire safety line cord and polarized plug.\* The third (green) wire in the line cord is connected to the chassis and the case of the unit. If a two terminal AC power receptacle in combination with an adaptor is used, it is imperative that the chassis of the power supply be returned to AC ground with a separate lead.
- b) DC GROUND. The DC output is isolated from the AC power line and from any direct connection to chassis or ground.\*\* The maximum voltage that can be supported between either output terminal and ground or chassis is 500V (DC or p-p) plus the maximum output voltage of the power supply. For lowest output ripple and noise the grounding of one side of the output is recommended.

\*Metered models only (suffix "M"). Unmetered models have a three (3) terminal barrier-strip for AC input. Terminal "G" on the barrier-strip is connected to chassis and case.

\*\*A capacitor-resistor network (C5, R25) is connected from the negative (-) output terminal to chassis. If the output is to be grounded elsewhere, this internal ground can be opened by removing C5 from the amplifier board (A1, FIG. 6-2).

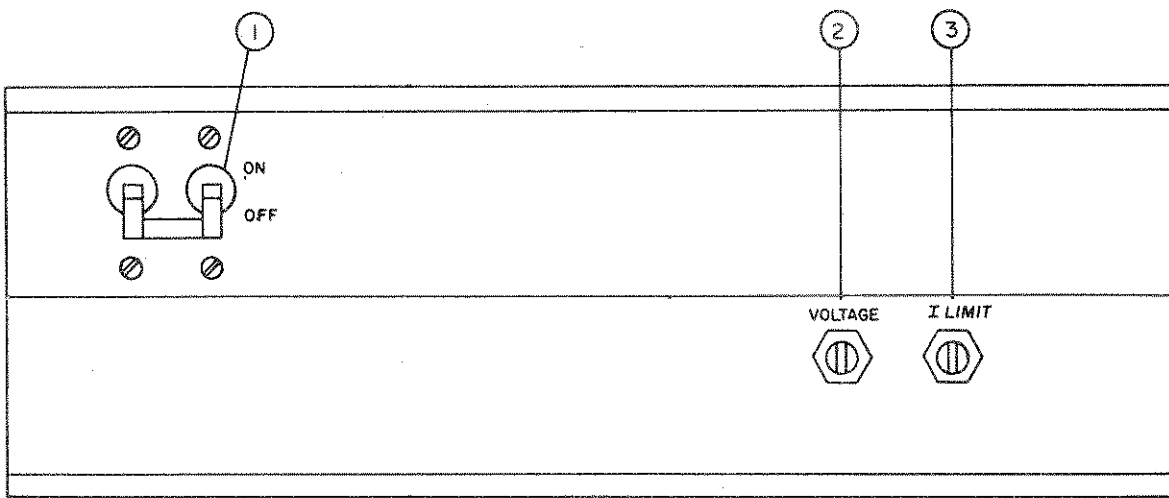

a) UNMETERED MODELS

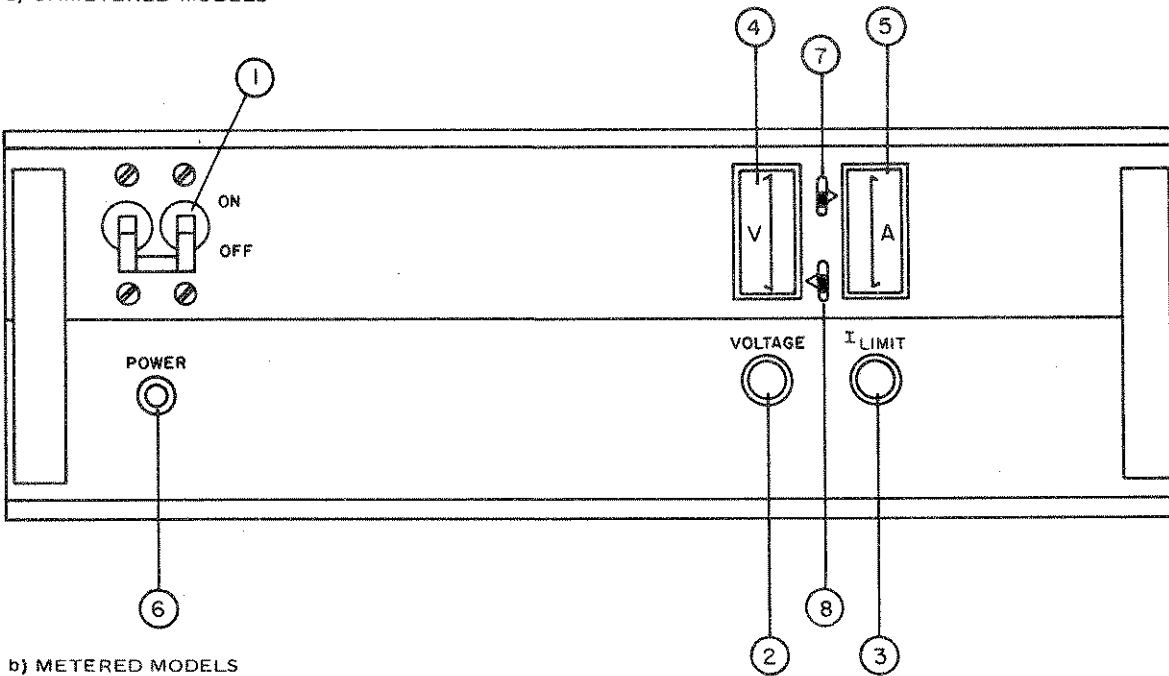

b) METERED MODELS

FIG. 2-3 FRONT PANEL CONTROLS AND TERMINATIONS

NO.	CONTROL OR TERMINATION	FUNCTION
1	AC POWER SWITCH/ CIRCUIT BREAKER	TURNS AC POWER LINE, "ON" OR "OFF" AND PROTECTS POWER SUPPLY INPUT CIRCUITRY
2	VOLTAGE CONTROL	ADJUSTS OUTPUT VOLTAGE FROM ZERO TO $E_0$ max.
3	CURRENT LIMIT CONTROL	ADJUSTS CURRENT LIMIT FROM 0-105% $I_0$ max.
4	VOLTMETER	MONITORS OUTPUT VOLTAGE, 0- $E_0$ max.
5	AMMETER	MONITORS OUTPUT CURRENT 0- $I_0$ max.
6	AC PILOT LIGHT	ENERGIZES WHEN AC POWER IS "ON"
7	METER RANGE SWITCH AMPERE	MAY BE SET TO FULL SCALE READING OF MAXIMUM OR 1/10 OUTPUT
8	METER RANGE SWITCH VOLTS	MAY BE SET TO FULL SCALE READING OF MAXIMUM OR 1/10 OUTPUT

TABLE 2-2 CONTROLS AND TERMINATIONS, FULL-RACK JOE MODELS, FRONT

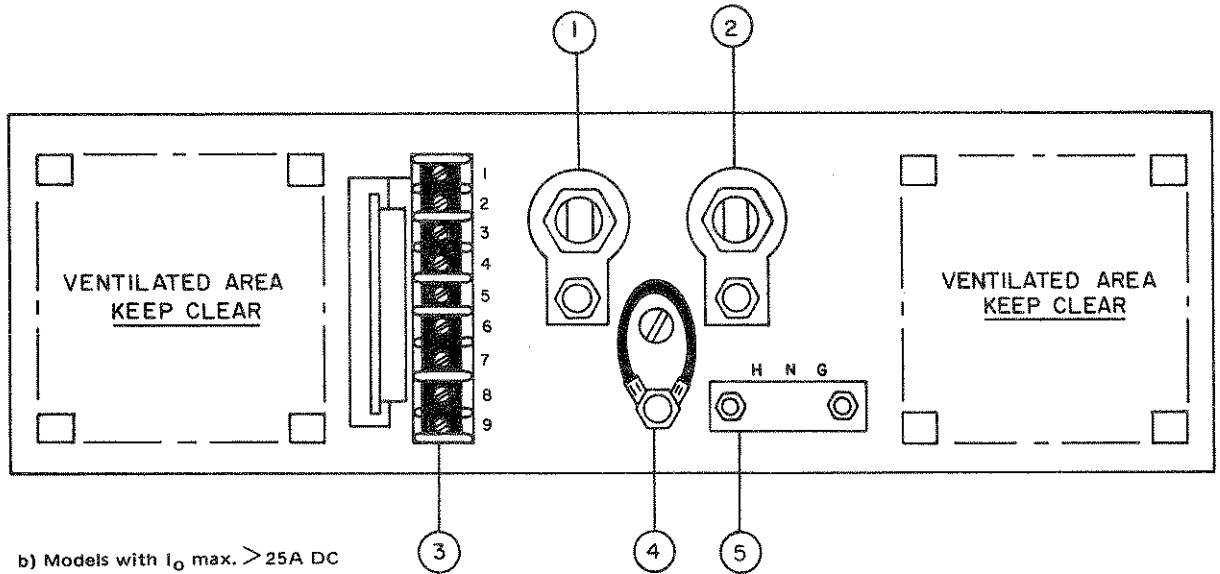
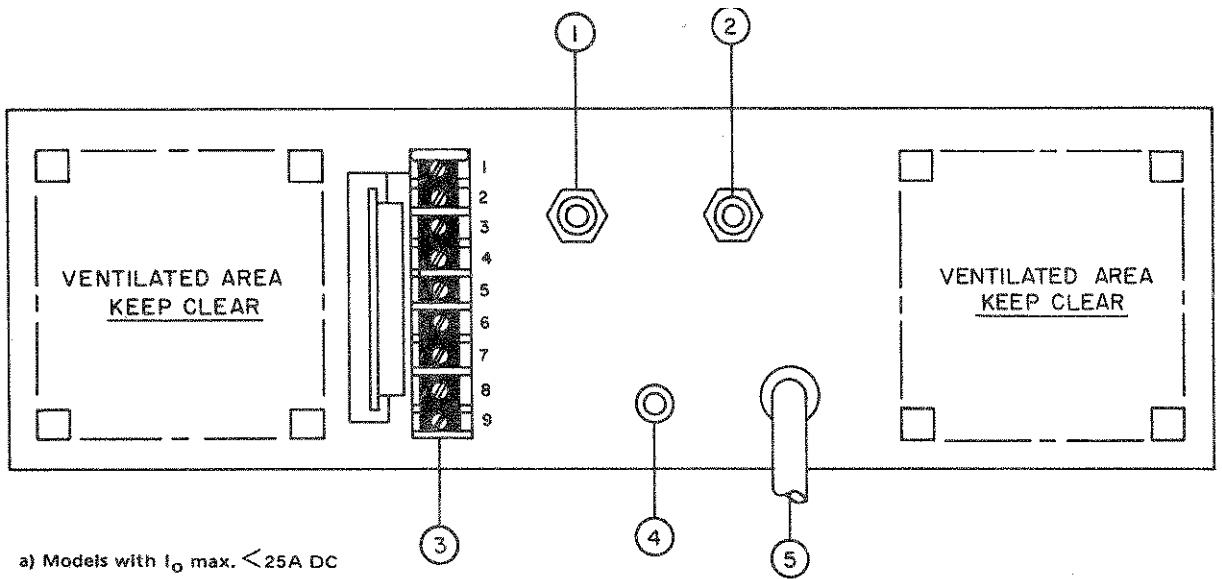
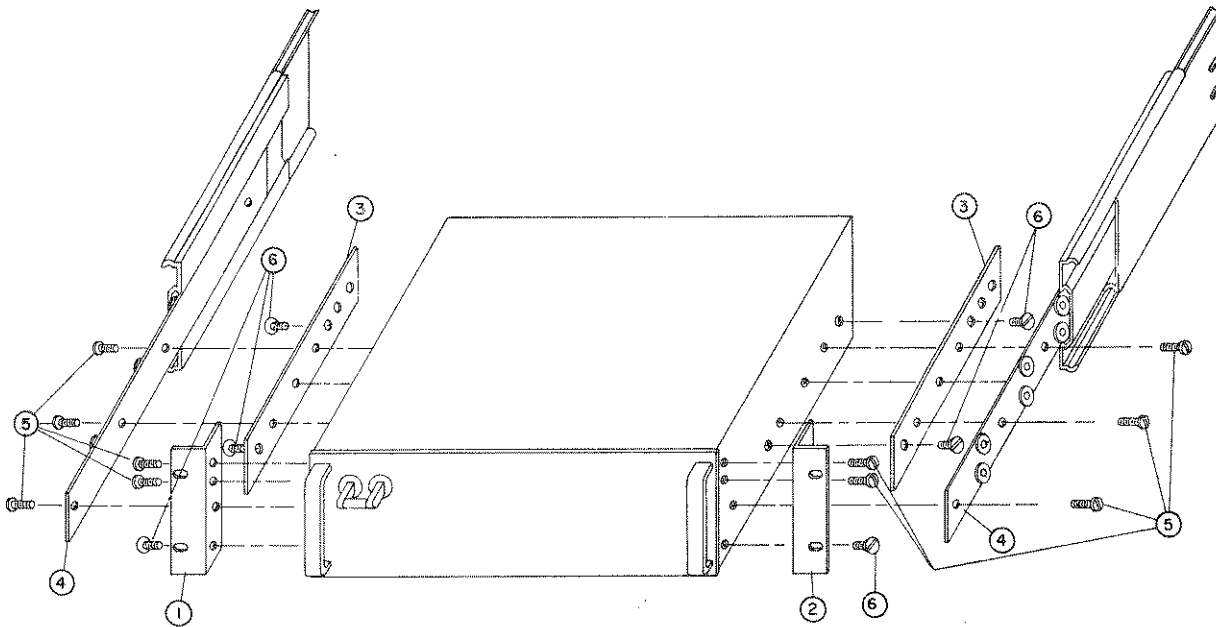

FIG. 2-4 REAR TERMINATIONS, FULL-RACK MODELS

NO.	TERMINATION	FUNCTION
1	(-) OUTPUT	NEGATIVE LOAD TERMINAL WITH GROUNDING POST*
2	(+) OUTPUT	POSITIVE LOAD TERMINAL WITH GROUNDING POST*
3	REAR BARRIER STRIP	PROGRAMMING AND MONITOR TERMINALS: (1) (+) OUTPUT MONITOR (2) (+) ERROR SENSING (3) (-) OUTPUT MONITOR (4) (-) ERROR SENSING (5) INTERNAL VOLTAGE CONTROL (6) NULL JUNCTION (AMPLIFIER INPUT) (7) REFERENCE RESISTOR (8) REFERENCE VOLTAGE (9) REFERENCE RESISTOR
4	CHASSIS CONNECTION	FLOATING GROUND LEAD TO GROUND EITHER (+) OR (-) OUTPUT VIA GROUND POST*
5	AC INPUT	3 WIRE SAFETY LINE CORD(METERED MODELS)OR INPUT BARRIER STRIP

\*Models with  $I_o$  max.  $> 25A$  DC only.

TABLE 2-3 REAR TERMINATIONS, FULL-RACK MODELS



RACK MOUNTING ACCESSORIES, PARTS LIST		
ITEM	DESCRIPTION	QTY.
1	FRONT ANGLE LEFT	1
2	FRONT ANGLE RIGHT	1
3	FILLER BRACKET	2
4	SLIDES: 110 QD JONATHAN SERIES	2
5	10-32 SCR BDG. HD.	10
6	10-32 FLATHEAD 82°	6

NOTE: ITEM (4) NOT SUPPLIED.

#### INSTRUCTIONS FOR SLIDE INSTALLATION

- 1) Items 1, 2, 3 are installed at the factory.
- 2) Item 3 (filler bracket) is predrilled and tapped for Jonathan Slides, Series 110 QD. Remove the three binding head screws on each side of Item 3. (These screws are part of Item 5.)
- 3) Line up slide with filler bracket and reinsert the binding head screws through the appropriate mounting holes in the slide.
- 4) If Jonathan Slide 110 QD-24-1 is used, an additional hole must be drilled into the slide. See FIG. 1-3 for further information.

FIG. 2-5 RACK INSTALLATION, "FULL RACK" MODELS.

NOTE: If slide installation (as described above) is not desired, other means of supporting the unit in the rear must be provided (additional rear brackets or a solid platform, for example) since the front angle brackets (Items 1, 2) alone are not sufficient to support the full weight of the unit.

## SECTION III – OPERATION

### 3-1 STANDARD POWER SUPPLY OPERATION, LOCAL CONTROL

3-2 GENERAL. The Power Supply is shipped from the factory with five (5) removable jumper links in place at the rear barrier strip (TB501) as shown in FIG. 3-1. THESE LINKS MUST BE IN PLACE AND SECURED TIGHTLY for standard local operation. Loose terminal links or wires at the barrier strip will cause malfunction of the power supply.

3-3 LOAD CONNECTION. The load may be connected in any of the two ways illustrated (FIG. 3-1,3-2). Load connecting wires should be as heavy as practicable, since load wire voltage drops will degrade regulation performance. Twisting of load wires will help to preserve the low output impedance of the power supply. To keep the DC voltage drop in the load connecting wires to a minimum, and to preserve the dynamic characteristics of the power supply (AC stability, output impedance and recovery time), load wires and error sensing leads should be as short and as large in diameter as practicable. Both lead pairs should preferably be tightly twisted. For minimum ripple and noise pick-up, the error sensing leads must be shielded. The shield, as well as one side of the output (preferably the positive), should be returned to the common ground point (Refer to FIG. 3-2).

**CAUTION**

THE LOAD MUST BE CONNECTED TO THE HEAVY DUTY OUTPUT TERMINALS AT THE REAR, NOT TO THE BARRIER STRIP. BARRIER STRIP TERMINALS ARE FOR MONITORING AND PROGRAMMING PURPOSES ONLY.

### 3-4 REMOTE ERROR SENSING

3-5 Specified regulation performance DIRECTLY AT THE LOAD requires the use of remote error sensing. A twisted, shielded pair of wires from the sensing terminals directly to the load will compensate for load wire voltage drops up to 0.5 volt per wire (Refer to FIG. 3-2). Observe polarities: The positive sensing wire [from terminal (2)] goes to the positive load wire.

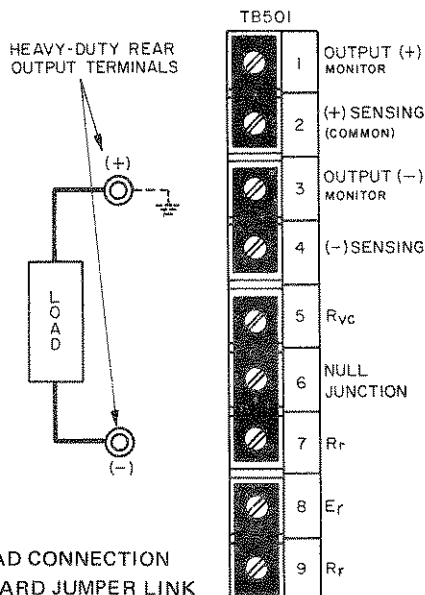

FIG.3-1 LOAD CONNECTION AND STANDARD JUMPER LINK CONNECTIONS WITHOUT ERROR SENSING

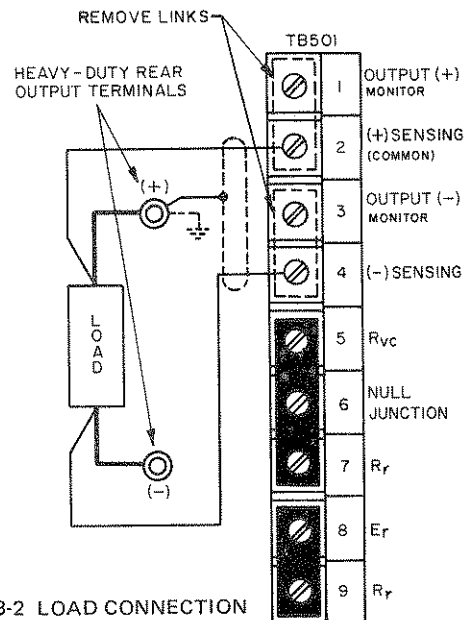

FIG. 3-2 LOAD CONNECTION USING REMOTE ERROR SENSING



### 3-6 OUTPUT ADJUSTMENT (Refer to FIG.'s 2-1 and 2-3 for the location of all controls)

- 3-7 a) Once the load is connected to the output terminals of the power supply as described in the previous paragraphs, the operating voltage may be adjusted to the desired value by turning the VOLTAGE CONTROL and observing the panel VOLTMETER.\* The CURRENT LIMIT CONTROL may be set fully clockwise, and will in this position provide over current protection at 105% of the maximum rated output current. The CURRENT LIMIT CONTROL may also be set to intermediate values, as desired, by first turning the AC POWER SWITCH to the "off" position and then placing a short circuit across the output. Turn AC line "on". Now the required operating current is adjusted by turning the CURRENT LIMIT CONTROL to the value needed plus  $\approx 2\%$ . The output current will now limit sharply at this value. After the short is removed from the output, the voltage protector can be set.
- b) (For Models equipped with Voltage Protector only.) With the "V Limit" control set fully clockwise, set the output voltage as described above. Turn the coarse "V Limit" control\*\* (R415) slowly counter clockwise, until the power supply output "crowbars", indicated by the output voltage going to zero and the circuit breaker shutting off. Turn the fine "V Limit" control (R414) slightly clockwise. The amount of "threshold" or difference voltage between operating voltage and the limiting point, is determined by this last adjustment, which should therefore be made with the "fine" control, R414. A too close adjustment towards the operating voltage may lead to spurious triggering, especially if the "delay" adjustment is set for maximum sensitivity. The minimum "threshold" voltage adjustable is 0.5 volt.) Adjust the "delay" capacitor (C413) if required. This control is factory adjusted for maximum sensitivity, consistent with reliable operation without spurious triggering. It needs re-adjustment only if extremely sensitive loads must be triggered in the shortest time possible and if some spurious triggering can be tolerated. Now the load can be connected to the power supply and operation can commence.

\*Use external metering for meterless models.

\*\*If model has only a "fine" control (R414), all VP Adjustments are made with this control.

### 3-8 INTRODUCTION TO REMOTE PROGRAMMING

- 3-9 GENERAL. A few general remarks may be in order to familiarize the user of this equipment with the terminology and basic equations pertaining to remote programming of Kepco Power Supplies. Electrically, the power supply, consists of the unregulated DC source ( $E_U$ ), the pass element ( $E_P$ ), the DC error amplifier (A) and a comparison circuit which resembles a four-arm electrical bridge. (Refer to FIG. 3-3). The elements of the bridge are arranged to produce a virtual zero at the amplifier input when the bridge circuit is at balance ( $V_{AA'} = 0$ ). Any tendency for the output voltage to change in relation to the reference voltage ( $E_R$ ) creates an error signal ( $e$ ) which, by means of negative feedback and the amplifier, tends to correct the output voltage towards restoration of bridge balance.

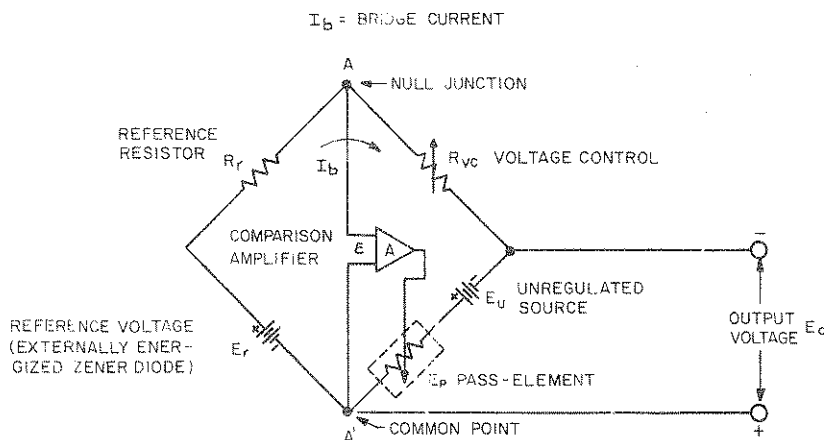

FIG. 3-3 KEPKO POWER SUPPLY CIRCUIT WITH COMPARISON BRIDGE (SIMPLIFIED)

### 3-10 EQUATIONS SHOWING THE OPERATION OF THE KEPCO BRIDGE

3-11 The following relationships govern the operation of the Kepco Bridge at balance, i.e., with  $V_{AA}' = 0$ :

$$a) \quad \frac{E_O}{E_r} = \frac{R_{VC}}{R_r} \quad (1)$$

$$\frac{E_r}{R_r} = I_b \quad (2)$$

$$E_O = I_b R_{VC} \quad (3)$$

Where:  $E_O$  = Output Voltage  
 $E_r$  = Reference Voltage  
 $R_r$  = Reference Resistance  
 $R_{VC}$  = Control Resistance  
 $I_b$  = Bridge or Control Current

- b) The ratio of the number of ohms control - resistance needed per volt output is termed the "CONTROL RATIO". It is normally 1000 ohm/volt in KEPCO Power Supplies.
- c) As can be seen from equation (1), the output voltage  $E_O$  can be controlled by varying any one of the three quantities. Rewriting equation (1) we have:

$$E_O = \frac{E_r}{R_r} \times R_{VC}$$

The ratio  $\frac{E_r}{R_r}$  constitutes the bridge or control current  $I_b$ . (Eq. 2).

- d) Therefore, we can write:  $E_O = I_b R_{VC}$  (Eq.3).  
Making  $I_b$  a precision quantity (precision bridge current adjustment is described in par. 3-16), establishes a precise programming ratio, so that the accuracy of  $E_O$  is solely dependent upon  $R_{VC}$ . This mode of operation is referred to as "RESISTANCE PROGRAMMING" and is covered in detail in Par. 3-19.
- e) Rewriting equation (1),  $E_O = E_r \frac{R_{VC}}{R_r}$ , we can make  $E_r$  the variable which controls  $E_O$ .

This type of control is referred to as "VOLTAGE PROGRAMMING" and is covered in Par. 3-25.

- 1) Many other modes of control are of course possible, some of them are described in the following paragraphs. For a more extensive treatment and a detailed theoretical view of power supply applications see the current KEPCO Application Literature, available from your Kepco Representative or directly from Kepco Applications Engineering Department.

NOTE: For all programming and adjustment components, use high quality, wire-wound, resistors with a T.C. of 20 p.p.m. or better.

### 3-12 ADJUSTMENTS FOR EXACT PROGRAMMING RATIO \*

- 3-13 Referring to equation (3):  $E_O = I_b R_{VC}$ , it is seen that if  $I_b = 1$  mA, 1000 ohms of control resistance ( $R_{VC}$ ) is needed for each volt of output. Making  $I_b$  therefore a precision quantity the accuracy and linearity of the output voltage will then solely depend upon  $R_{VC}$ .
- 3-14 Again referring to equation (3), we see that if  $R_{VC} = 0$  (shorted out), the output voltage should be zero. A small negative offset voltage (in the millivolt range) exists however under this condition at the output.
- 3-15 Both inaccuracies, the slightly larger bridge current ( $I_b$ ) and the small negative offset voltage ( $E_{iO}$ ) may be adjusted to provide a linear and precise programming ratio. Refer to FIG. 2-1 for the location of the calibration controls.
- 3-16 PROCEDURE. PRECISION PROGRAMMING RATIO ADJUSTMENT (Refer to FIG. 3-4)

- a) Equipment Required:
- 1) Precision digital or differential voltmeter (M1).
  - 2) Precision resistor, accuracy comparable to M1. The value is not important, but must be known. For every 1000 ohms, 1 volt will appear across M1. ( $R_{VC}$ ).
  - 3) Single pole, single throw switch (S1).

\*Applicable for models with suffix "E" only.

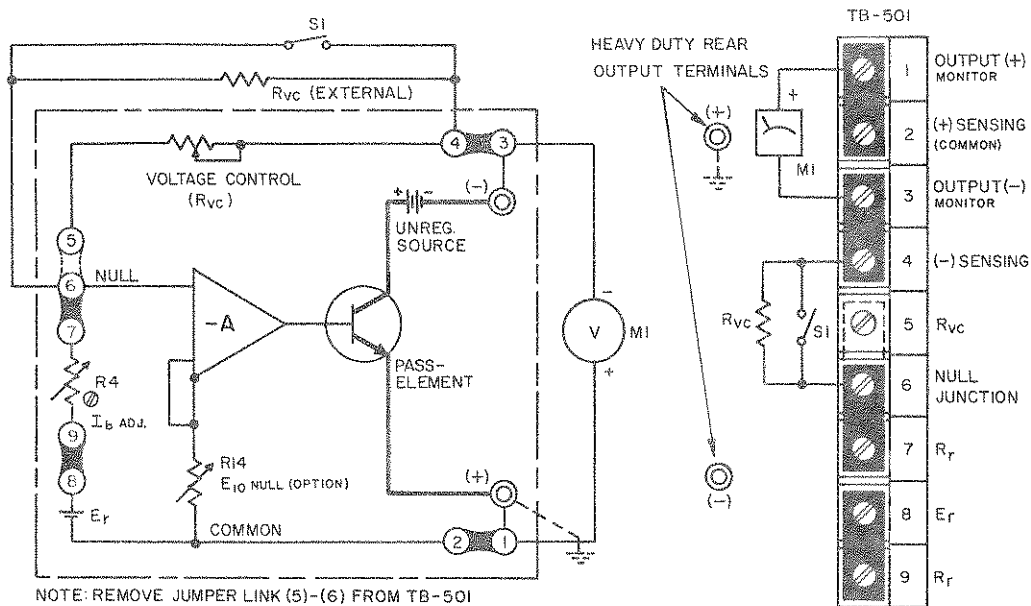

FIG. 3-4 CONNECTIONS FOR PRECISION PROGRAMMING RATIO ADJUSTMENT

- b) Connect calibration set-up as shown in FIG. 3-4 and connect the power supply to the AC power line.
- c) With S1 "open", and  $R_{vc} = 5\text{ K ohms}$ , approximately 5 volts will be read-out on M1. Adjust R4 ( $I_b$  adjustment) until exactly 5 volts are read-out on M1.
- d) Close S1 and note deviation from zero on M1 (approx. 2 to 8 mV negative). Adjust R14 (zero adjustment) until exactly zero volts read-out on M1.
- e) Open S1 and check the 5 volt reading. Repeat "c" and "d" as necessary to achieve the desired accuracy. FIG. 3-5 below shows graphically how the programming ratio can be precision adjusted.

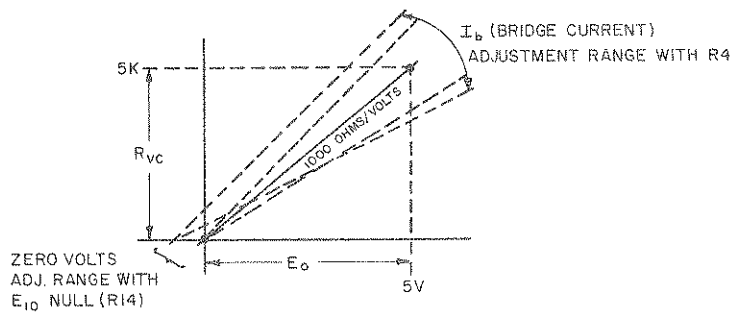

FIG. 3-5 ESTABLISHING PROGRAMMING LINEARITY

### 3-17 GENERAL RULES FOR REMOTE PROGRAMMING

3-18 All remote programming applications require the observance of a few basic rules to insure proper functioning of the power supply in the particular mode of operation selected. These rules should be remembered before each application and especially if malfunctioning of the programming set-up is experienced.

- 1) **GROUNDING.** Ground loops due to multiple and indiscriminant grounding of various equipment are the cause of the majority of complaints about "high ripple or noise". They can be easily avoided by grounding the power supply at one point only to which all shielded cables and equipment cases are connected. If possible, one side (preferable the positive one) of the power supply output should also be grounded. Frequently, high ripple is introduced by programming sources or instruments used at the input (null junction) although all grounding rules have been observed. This may be due to the external instruments or source's close coupling to the AC line. In these cases only isolation (i.e. battery operated devices) is the answer. It must also be remembered that input and output of the power supply are "common", so that if the output is not grounded, the input source must be isolated for the maximum output voltage to be programmed, plus the amount of voltage the common is "off ground".
- 2) **CONNECTIONS.** All external connections, especially the rear barrier strip terminal screws, must be tight. Series malfunctions may be caused by open feedback loops or programming connections.
- 3) **INPUT SOURCES.** If specified performance is expected when remote programming, external input or reference sources must have specifications equal to or better than that of the power supply.
- 4) **PROGRAMMING RESISTORS** Programming resistors should be high quality wirewound units with temperature coefficients of 20 parts per million or better. Their wattage rating must be at least 10 times the actual power dissipated. Although the control current through these resistors is only 1 mA, an error current exists when programming large voltage excursions. The magnitude of this error current equals the change in output voltage, divided by the final resistance of the programming resistor. (If, for example, the voltage step is from 50 volts to zero, ( $\Delta E_O = 50$  V) and the final resistance of the programming resistor is  $\Delta R_{VC} = 2$  ohms,  $I_{peak} = 25$  A. The duration of the peak error current depends upon the size of the output capacitor.  $I_{peak}$  decays exponentially as the output voltage assumes the final value.
- 5) **EXTERNAL SWITCHING.** If step-switch devices are used in resistance programming, they must be of the "make before break" variety to avoid programming infinity. Programming resistors must have a voltage rating at least equal to the maximum output voltage of the power supply.

### 3-19 OUTPUT VOLTAGE PROGRAMMING WITH EXTERNAL RESISTANCE

The output voltage of the Power Supply may be controlled remotely by an external resistance, replacing the built-in voltage control resistance which is disconnected at the rear barrier strip. The value of the programming resistance may be calculated by referring to the transfer function derived earlier (Eq.1):

$$E_O = R_{VC} \times \frac{E_r}{R_r}$$

Since  $\frac{E_r}{R_r} = I_b$  (2), it follows that  $E_O = I_b R_{VC}$  (3)

Referring to Equation (3), we see that since  $I_b$  is 1 mA in KEPCO Power Supplies (and can be precisely adjusted as shown in Par. 3-12), for every volt of output, 1000 ohms control resistance must be provided. This corresponds to a "Programming Ratio" of 1000 ohms per volt.

### 3-20 PROCEDURE (Refer to FIG. 3-6)

- a) Determine value of programmin resistor(s) for output voltage desired.
- b) Using two-wire, shielded cable, connect the chosen resistors to terminals (4) and (6). Connect the shield to the "ground" terminal.
- c) The output voltage will vary from zero to  $(1 \text{ mA}) \times (R_{VC})$ , as  $R_{VC}$  is adjusted from zero to its maximum value.

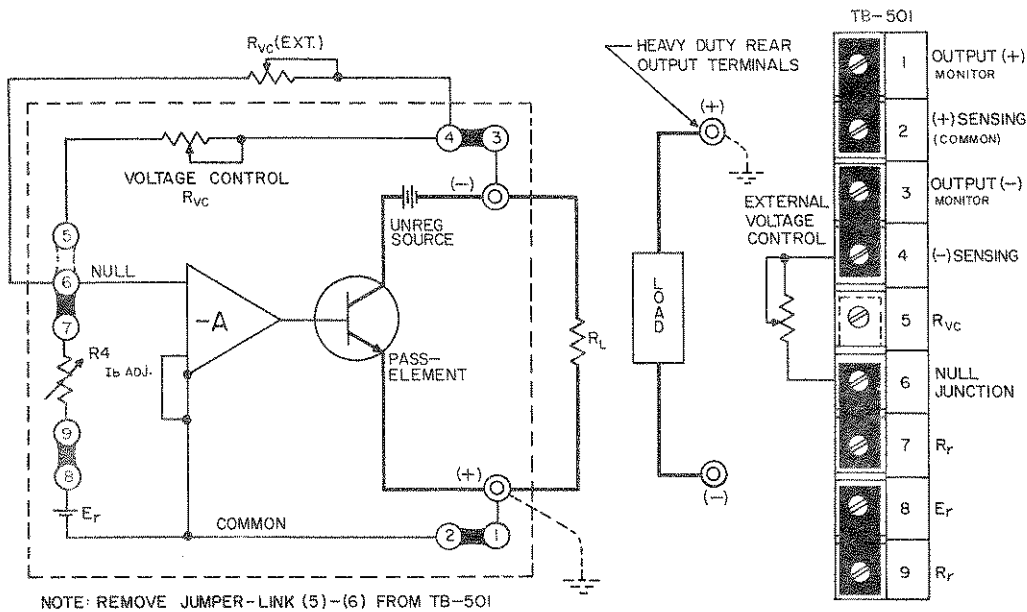

FIG. 3-6 REMOTE RESISTANCE PROGRAMMING

**3-21 PROGRAMMING BY CONDUCTANCE:**

3-22 For special applications, the output voltage  $E_o$  can be adjusted by varying the bridge current. The relationship governing this type of programming is:

$$E_o = E_r (R_{vc}) (G), \text{ (Eq. 4)}$$

or

$$E_o = \frac{E_r}{R_r + R_x} \times (R_{vc})$$

Where:  $G = \frac{1}{R_r + R_x} = \text{programming conductance}$

$E_o$  = output voltage  
 $E_r$  = reference voltage  
 $R_{vc}$  = control resistance  
 $R_r$  = reference resistance  
 $R_x$  = programming resistor

Since  $\frac{E_r}{R_r} = I_b$  and  $E_o = I_b R_{vc}$ , the output voltage varies directly as  $I_b$  changes. Changing  $I_b$  with the help of an additional resistor in series with  $R_r$  results in an inversely proportional change of  $I_b$ , since now

$$I_b = \frac{E_r}{R_r + R_x}$$

This method of output voltage adjustment is therefore referred to as conductance programming.

3-23 Conductance programming is a reciprocal function when analyzed in terms of resistance, but perfectly proportional

$$E_o \propto \frac{1}{R_x}$$

It can be very useful, especially over a limited range and for small changes in output voltage. Another distinctive advantage of this type of programming is the "built-in" safety feature. Should the programming circuit open accidentally, the programming resistance becomes infinite, the conductance is zero, and consequently, the output voltage becomes zero.

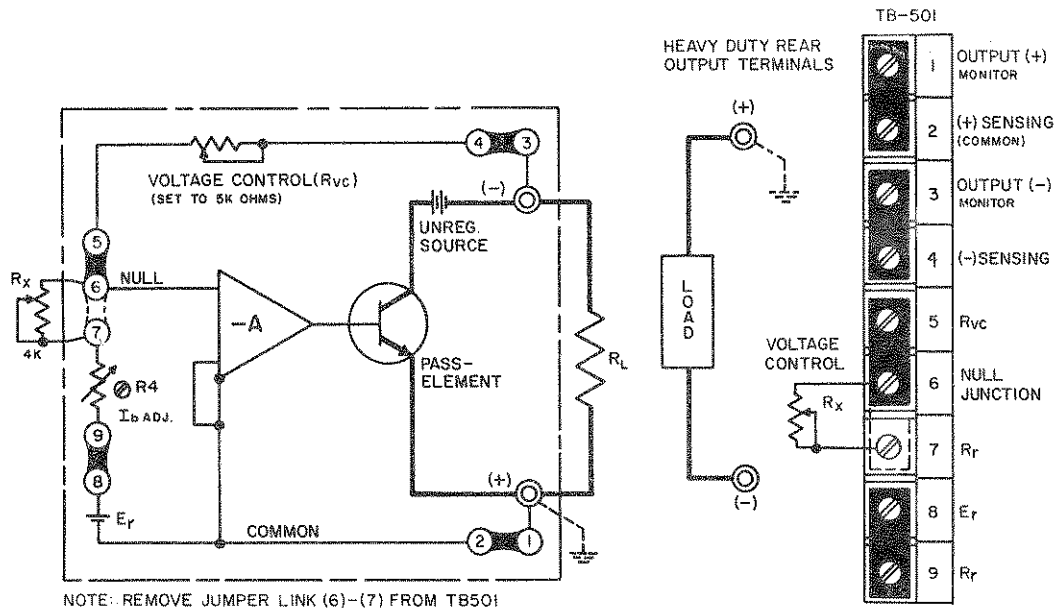

FIG. 3-7 REMOTE CONDUCTANCE PROGRAMMING

3-24 PROCEDURE (Refer to FIG. 3-7)

EXAMPLE:  $E_O$  desired = 3 to 5 volts.

- a) Select  $R_{VC}$  for maximum desired output voltage  $E_O$ .

$$R_{VC} = \frac{E_O}{I_b}; R_{VC} = \frac{5V}{1 \text{ mA}} = 5 \text{ K ohms.}$$

Set built in  $R_{VC}$  to 5 K ohms, or disconnect and use external resistor.

- b) A change of  $E_O$  to 3 volts requires a bridge current change of:

$$\Delta I_b = \frac{\Delta E_O}{I_b} = \frac{2 \text{ volts}}{5 \text{ K ohms}} = .4 \text{ mA}$$

- c) Since  $I_b = \frac{E_r}{R_r} = 1 \text{ mA}$ , the additional resistance needed is:

$$I_b (R_r + R_x) = E_r; R_x = \frac{E_r}{I_b} - R_r \text{ or } R_x = \frac{6 \text{ volts}}{0.6 \text{ mA}} - 6 \text{ K} = 4 \text{ K ohms.}$$

A 4K ohm, WW, low T.C. potentiometer, connected as shown in FIG. 3-7, will change the output voltage from 3 to 5 volts when varied from zero to 4K ohms.

NOTE: A word of caution may be in order in regard to the changing of the bridge current. The 1 mA value has been selected for maximum stability in the zener reference circuit. A large departure from this value is not advisable. If a  $\pm 50\%$  change in  $I_b$  is not sufficient to achieve the desired voltage swing, an external reference supply can be used.

### 3-25 REMOTE PROGRAMMING WITH EXTERNAL CONTROL VOLTAGE

3-26 The output voltage of KEPCO power supplies may be controlled by an external, variable voltage source, which supplies the necessary control current, formerly delivered by the (now disconnected) internal, fixed reference source. This mode of operation is termed "Voltage Programming". It can be mathematically expressed by referring to basic equation (1):

$$\frac{E_o}{E_r} = \frac{R_{vc}}{R_r} \quad (\text{Eq. 1})$$

Solving for  $E_o$ , and designating the external programming components " $E_i, R_i$ "

the result is:

$$E_o = -E_i \times \frac{R_{vc}}{R_i} \quad (\text{Eq. 5})$$

3-27 As seen from the expression (Eq.5), if the ratio  $R_{vc}/R_i$  (which represents the closed loop gain of the system) is held constant,  $E_o$  will vary linearly with  $E_i$ , the external programming voltage. The above expression (Eq.5) is seen to be similar to the operational amplifier transfer function in the inverting configuration. The voltage programmed power supply does in fact become a unipolar power amplifier with potentially very high power gain but with limited frequency response. (Refer to FIG. 3-8). The limited frequency response is largely due to the effect of the output capacitor ( $C_o$ ) acting as a low-pass filter and preventing the output voltage ( $E_o$ ) from varying rapidly. The output voltage may be varied over the full range, bounded on the high end by the maximum rated value. A practical example to illustrate component selection will be given below.

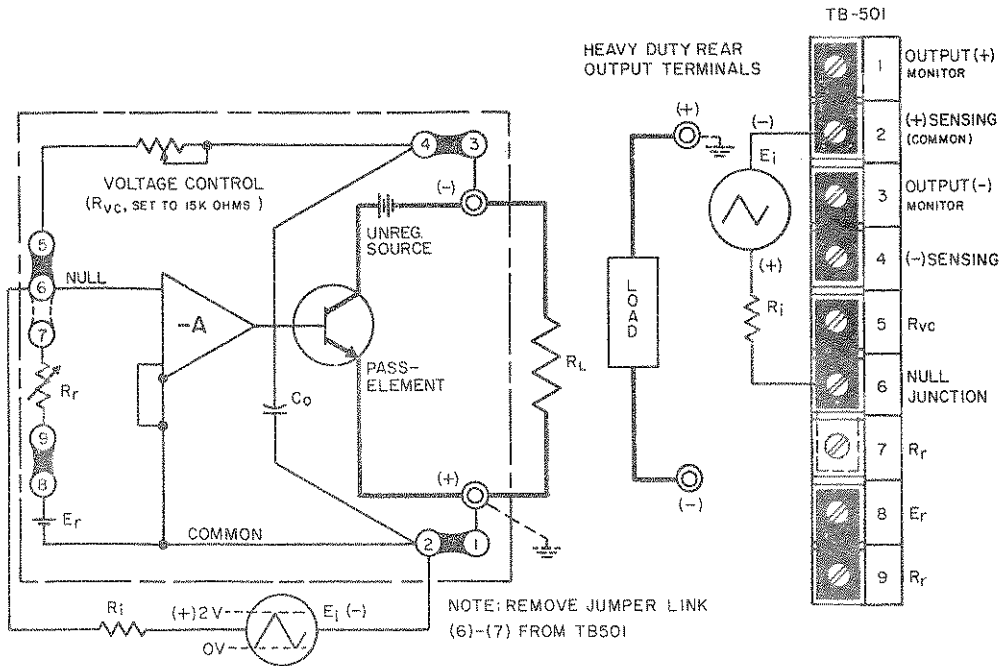

FIG. 3-8 THE POWER SUPPLY IN THE OPERATIONAL AMPLIFIER MODE

3-28 Example: A power supply with a rated maximum output voltage of 15 volts is to be voltage programmed over its full range (0 to 15V) by a triangular, positive increasing source with a peak output voltage ( $E_i$ ) of 2 volts, and able to deliver at least 1 mA control current. Since the required voltage gain is:  $E_o/E_i = 15/2 = 7.5$ , the ratio  $R_{vc}/R_i$  must also equal 7.5. If the internal voltage control is retained, in this case, since  $R_{vc} = 15 \text{ K ohms}$ ,  $R_i$  must equal  $15 \text{ K}/7.5 = 2 \text{ K ohms}$ . FIG. 3-8 shows the Power Supply as an operational amplifier and the necessary rear barrier connections for this mode of operation.

### 3-29 CONSTANT CURRENT OPERATION

3-30 A KEPCO power supply can be set up to deliver constant current by the addition of an external sensing resistor and a current control. In the constant current operating mode, the voltage comparison bridge is interconnected with an external current sensing resistor,  $R_S$ , and a current control,  $R_{CC}$  (as shown in FIG. 3-9) to maintain a constant voltage drop across  $R_S$ . In this way, an adjustable constant load current is obtained. Characteristic of the constant current supply is ability to change its output voltage automatically in order to maintain a constant current through a range of possible load resistances. The range of output voltage that the supply can deliver and simultaneously maintain constant current, is referred to as the "COMPLIANCE VOLTAGE".

3-31 The current sensing resistor  $R_S$  is chosen to develop a 0.5 volt drop at the maximum desired current.\* It is calculated by dividing this current into 0.5 volt. The value of  $R_S$  is not critical and can be the nearest standard resistance available. Several facts should be kept in mind however, when choosing  $R_S$ . A compromise must be made between a large and a small value. While a large value is desirable for good current regulation, it is less so in view of the power dissipated across it. It must be remembered that all the load current is flowing through  $R_S$  and the input to the regulator is connected across it. It is therefore vital that all extraneous changes across  $R_S$ , i.e. resistance change due to temperature, are kept to a minimum. A high quality, low T.C. (20 PPM) resistor, at least ten times the actual wattage needed, is therefore strongly recommended. In practice,  $R_S$  is usually selected for a 0.5 volt sample at maximum output current desired.\* If more than a 10:1 ratio of output current is needed, several values of  $R_S$  should be selected and switched in or out as required.

\*For KEPCO Power Supplies with maximum rated output currents of 5 A DC or less, a 1 volt sample at the maximum desired current should be used.

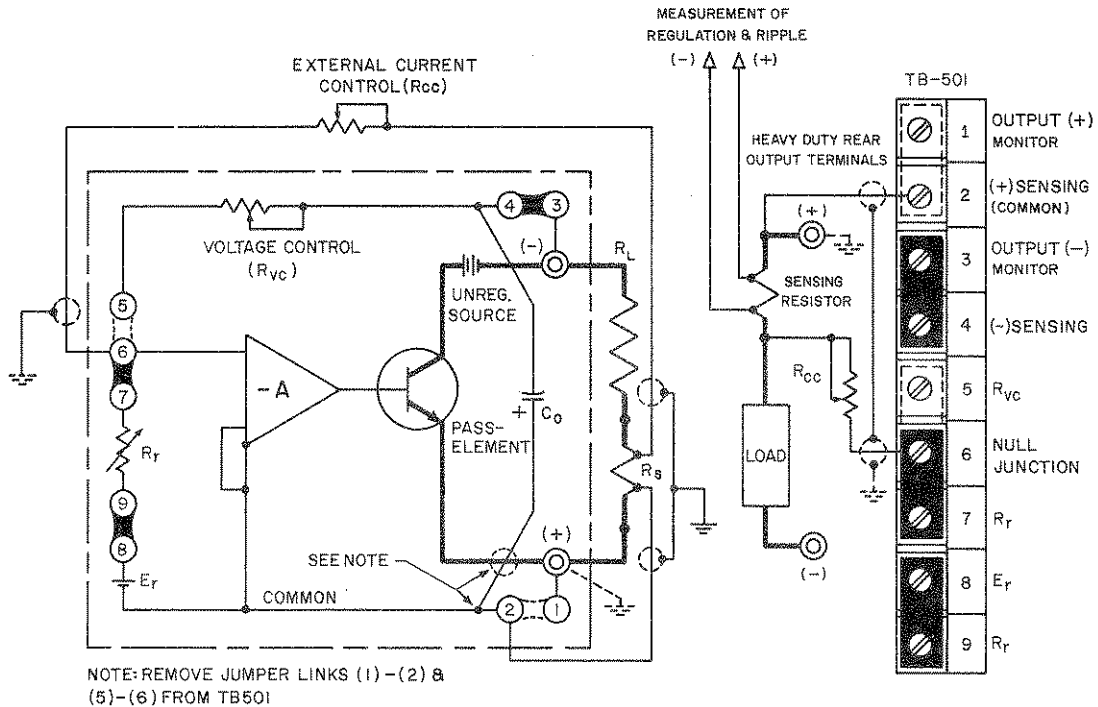

FIG. 3-9 CONSTANT CURRENT OPERATING MODE

**NOTE:**  $R_S$  should be physically located as close to the (+) output terminal of the power supply as possible. If, however, long output and sensing leads cannot be avoided, the (+) terminal of the output capacitor ( $C_O$ ) must be internally reconnected from the (+) sensing to the (+) output terminal.



3-32 The current control resistor,  $R_{CC}$  is chosen on the basis of the control ratio of the Kepco comparison bridge, and  $V_S$  the maximum voltage across  $R_S$ . If  $R_S$  was selected for 0.5 volt drop, then  $V_S = 0.5$  volt and  $R_{CC} = V_S$  times (control ratio), or

$$R_{CC} = 0.5 \text{ volt} \times \frac{1000 \text{ ohm}}{\text{volt}} = 500 \text{ ohms. A high quality, low T.C. (20 PPM) resistor is recommended}$$

for  $R_{CC}$ .

3-33 PROCEDURE (Refer to FIG. 3-9)

The actual component calculation for current regulation is perhaps best shown by a practical example. A KEPCO Power Supply with a rated maximum output current of 50 A DC is to be set up for current regulated output from 5A to 50A (1:10 ratio).

a)  $R_S$  is chosen by:  $R_S = \frac{0.5 \text{ volt}}{50 \text{ A}} = 0.01 \text{ ohm.}$

$$P_{diss} = V_S \times I_{max.} = 0.5 \text{ volt} \times (50 \text{ A}) = 25 \text{ watts. (use 250 watt)}$$

NOTE: A heavy duty, 4 terminal meter shunt or a power resistor in the TEPRO "TMK" series is required. Inquire at KEPCO if special values are needed.

b) The control resistance  $R_{CC}$  is found by calculating its limits:

$$R_{CC} \text{ (max.)} = V_S \text{ (max.)} \times \text{control ratio} = 0.5 \text{ V} \times \frac{1000 \text{ ohms}}{\text{V}} = 500 \text{ ohms.}$$

$$R_{CC} \text{ (min.)} = V_S \text{ (min.)} \times \text{control ratio} = 0.05 \text{ V} \times \frac{1000 \text{ ohms}}{\text{V}} = 50 \text{ ohms.}$$

As  $R_{CC}$  is therefore varied from 50 ohms to 500 ohms, the regulated current will vary from 5 to 50 mA. The compliance voltage will change in the same ratio (10:1), its absolute value depending on the load resistance used.

c) A large output current range (1 mA to 50 A) could be covered if three separate sensing resistors were to be calculated on the basis of a 0.5 volt sample at maximum current:

a)  $R^1_S$  (For 5 to 50 A) =  $0.5 \text{ V}/50 \text{ A} = 0.01 \Omega$  (250 watt)

b)  $R^2_S$  (For 0.5 to 5 A) =  $0.5 \text{ V}/5 \text{ A} = 0.1 \Omega$  (25 watt)

c)  $R^3_S$  (For 0.05 mA to 0.5 A) =  $0.5 \text{ V}/0.5 \text{ A} = 1 \Omega$  (2.5 watt)

### 3-34 SERIES OPERATION OF KEPCO POWER SUPPLIES

3-35 GENERAL. Kepco Power Supplies can be series-connected for increased voltage output, provided the specified limits on voltage to chassis are not exceeded. When series-connected, the supplies should be protected by means of a semiconductor diode across the output terminals of each power supply, as shown in FIG. 3-10. The peak inverse rating of these diodes must be at least as large as the output voltage of the supply to which they are connected. The continuous current rating of the diodes should be at least as great as the largest short-circuit current of the interconnected supplies.

3-36 Two basic series connection methods are generally used, the "Automatic Series Connection", as illustrated in FIG. 3-10, and the "Master-Slave" connection, shown in FIG. 3-11. The basic difference between these two alternate methods lies in the manner of the output control. While in the "Automatic" connection the outputs of both supplies may be controlled individually, in the "Master-Slave" connection, control is exercised from the "Master" supply alone, while the "Slave" supply follows the master command in a ratio which may be pre-determined by the user. The latter method of series operation is therefore frequently termed "Automatic Tracking".

### 3-37 PROCEDURE FOR AUTOMATIC SERIES CONNECTION

- a) Connect load as shown in FIG. 3-10. Keep voltage drop in load wires as low as practical by using heavy gauge wire.
- b) Connect protective diodes across respective output terminals.
- c) Remove jumpers as shown and connect error sensing leads. These leads should also be as heavy as practicable, and should be twisted and shielded.
- d) Turn supplies on and adjust voltage on either control as required.

3-38 The "Master-Slave" series connection method is illustrated in FIG. 3-11. As seen from the figure, the reference voltage ( $E_r$ ) of the "Slave" supply is disconnected and its input or null junction is connected to the output of the "Master" supply via the tracking resistor ( $R_t$ ). The "Slave" supply output is thus completely dependent on the "Master" output voltage:

$$E_{Os} = E_{Om} \frac{R_{Vcs}}{R_t} , \text{ where: } \begin{array}{l} E_{Om} = \text{Output Voltage, Master} \\ E_{Os} = \text{Output Voltage, Slave} \\ R_t = \text{Tracking Resistor} \\ R_{Vcs} = \text{Voltage Control Resistance, Slave} \end{array}$$

As evident from the equation above, if the tracking resistor ( $R_t$ ) value is equal to that of the voltage control resistor of the "Slave" supply ( $R_{Vcs}$ ), a "tracking ratio of 1:1 is achieved and the output of the "Slave" will equal that of the "Master". If a single load is connected to the series "Master-Slave" combination, twice the "Master" output voltage is applied to it. If separate loads are connected, identical voltages are applied to the individual loads.

3-39 The ratio  $E_{Os}/E_{Om}$  can be readily changed if the application so requires by simply altering the value of either  $R_{Vcs}$  or  $R_t$ . In practice, since  $R_{Vcs}$  is the ten-turn voltage control rheostat of the "Slave" supply, the tracking resistor ( $R_t$ ) is selected for the desired tracking ratio. The value of  $R_{Vcs}$  is determined from the parts list and  $R_t$  is selected accordingly to the selected ratio. For a 1:1 ratio  $R_t = R_{Vcs}$ , for a 1:2 ratio,  $R_t = 1/2 R_{Vcs}$  etc.

### 3-40 PROCEDURE FOR MASTER-SLAVE SERIES CONNECTION

- a) Connect load as shown in FIG. 3-11. Keep voltage drop in the load wires as low as possible by using heavy gage wire.
- b) Connect protective diodes across the respective output terminals.
- c) Remove jumper links as shown (FIG. 3-11) and connect error sensing leads if remote sensing is desired. Sensing leads should be twisted and shielded.
- d) Select value of the tracking resistor ( $R_t$ ) and connect with shielded wire as shown (FIG. 3-11).
- e) Turn supplies "on", and adjust output voltage on the "Master" Voltage Control as desired.

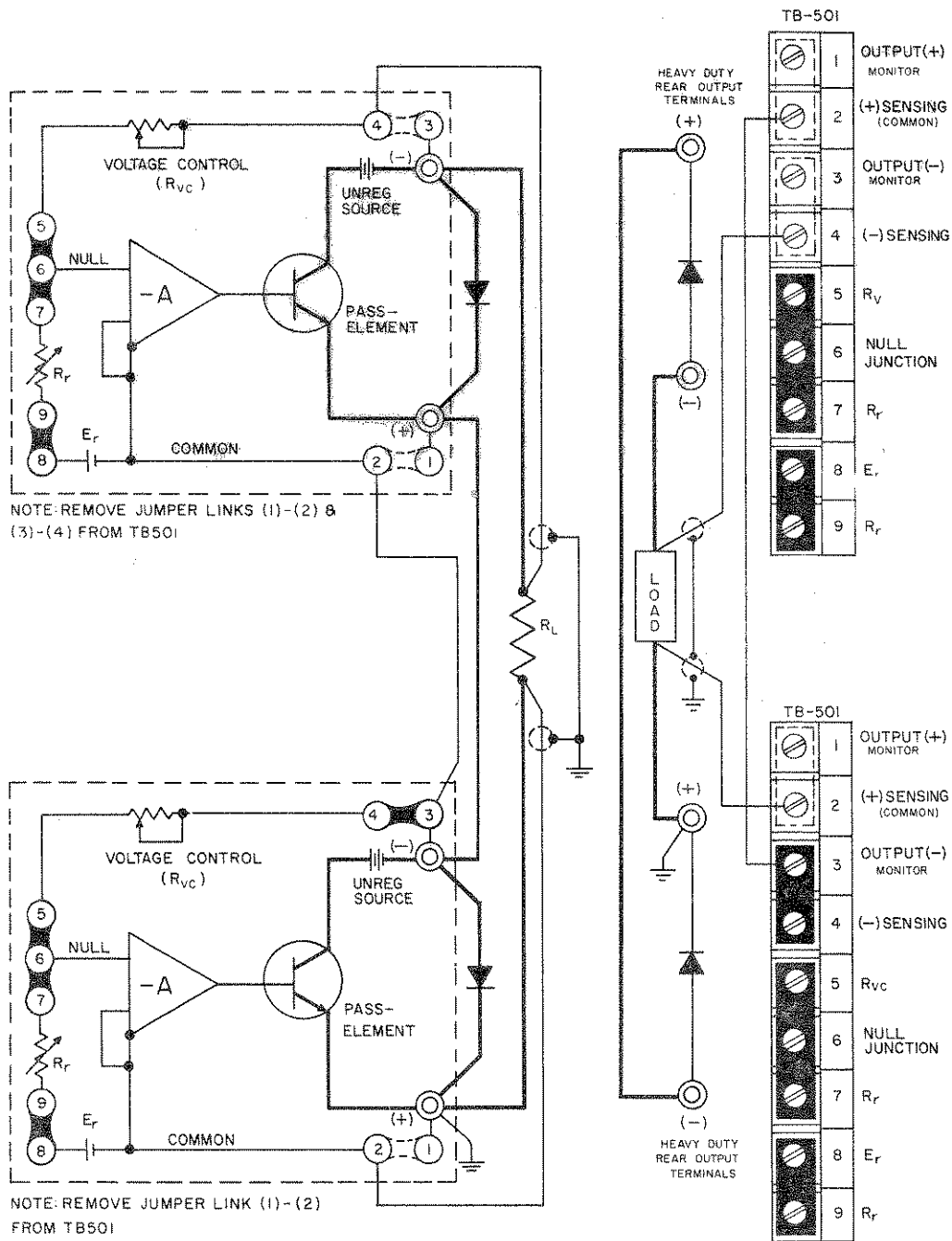

FIG. 3-10 AUTOMATIC SERIES CONNECTION OF KEPKO POWER SUPPLIES

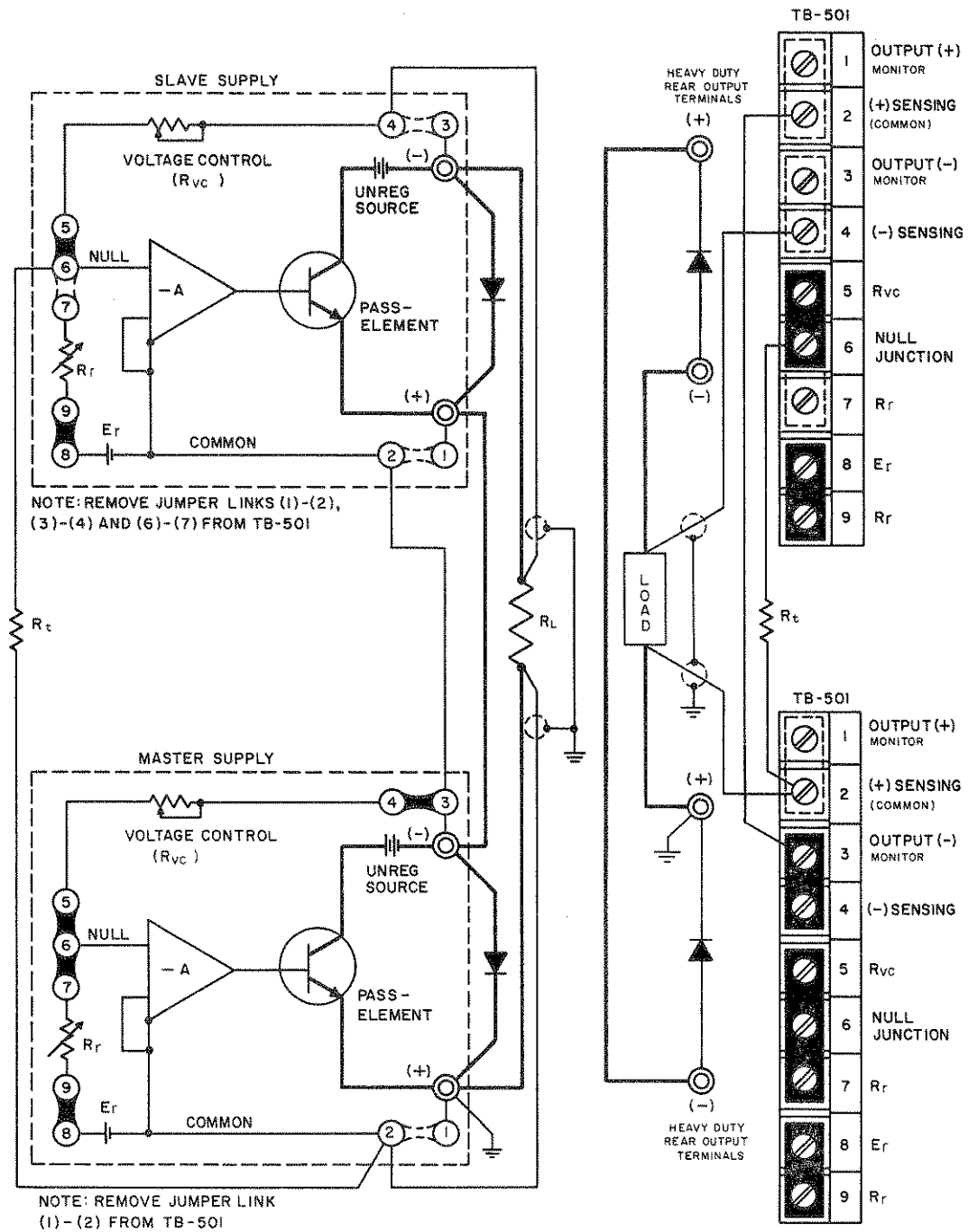

FIG. 3-11 MASTER-SLAVE SERIES CONNECTION OF KEPKO POWER SUPPLIES

## PARALLEL OPERATION

**GENERAL.** Kepco power supplies equipped with an overvoltage crowbar (all CPS models and JOE models with suffix "VP") cannot be operated in parallel for increased output current. A triggered crowbar in a power supply working in a parallel configuration would have to absorb the total output current of the other power supplies.

**EMERGENCY SITUATIONS.** Sometimes a situation arises where additional output current is required and only power supplies with lower than required current ratings are available. In these cases, the power supplies can be paralleled if the crowbar circuit in each unit is disabled. Refer to the component location drawing for assembly A4 (Section VI of this manual) and remove R402 from the overvoltage protector assembly (A4). If overvoltage protection is considered essential in the application at hand, a separate crowbar circuit, rated for the *total* output current in the parallel connected power supplies must be used. (Refer to Kepco VIP models.) Two basic methods of paralleling power supplies are described in pars. 3-41 to 3-46. **USE PARALLELING IN EMERGENCIES ONLY. CROWBAR CIRCUITS MUST BE DISABLED.**

### 3-41 PARALLEL OPERATION (AFTER DISABLING THE CROWBAR CIRCUIT ONLY)

3-42 **GENERAL.** As in the previously described "series" connections, an "Automatic" or a "Master/Slave" connection method can be chosen. The choice between the two methods will depend on the application at hand. For constant loads or small load variations (load changes *smaller* than the maximum output range of a *single* power supply), the "Automatic" parallel connection can be used. For load changes *exceeding* the maximum rating of a *single* power supply, the "Master/Slave" method is suitable. For either method, some general rules should be observed:

- 1) Parallel *only* supplies which can be adjusted to the same compliance (output) voltage.
- 2) Error sensing, as shown in the following diagrams, can be used to compensate for load wire voltage drops.
- 3) Load wires should be *as short as practicable*. Select wire gauge *as heavy as possible* and twist wires tightly. Approximately *equal* lengths of wire should be used.
- 4) *Common* a-c power source "turn-off" for all supplies is recommended.

### 3-43 AUTOMATIC PARALLEL CONNECTION

3-44 **PROCEDURE FOR AUTOMATIC PARALLEL CONNECTION (See FIG. 3-13)**

- 1) Connect the power supplies to be paralleled to a common a-c source (preferably with a common "on-off" power switch).
- 2) *Without* connecting the power supplies to the load or to each other, turn a-c power "on," and adjust the output voltage on each supply to the required compliance voltage.
- 3) Adjust *both* "current" controls to their maximum (extreme clockwise) position. Turn a-c power "off."
- 4) Make all load interconnections as shown in the connection diagram (refer to FIG. 3-13) *except the error sensing connections* (these connections may be added later if needed).
- 5) With the *individual* a-c power switches of the two power supplies in the "on" position, turn *common* a-c power switch "on." Observe output current meters on *both* units. Since the initial output voltage adjustments were not identical, *one* of the power supplies (to be designated SUPPLY #1) will be at a slightly higher output voltage than the other (to be designated SUPPLY #2). Consequently, SUPPLY #1 will deliver its maximum load current and will operate in the current limit mode. The rest of the load current is delivered by SUPPLY #2, which is operating in the voltage mode.

- 6) The "current" control of SUPPLY #1 can now be adjusted, as to equalize the total load current between SUPPLY #1 and SUPPLY #2, and operation can proceed. ERROR SENSING CAN BE USED FROM SUPPLY #2 ONLY.

**NOTE:** The diagram below (refer to FIG. 3-12) shows how the two power supplies operate in the parallel mode. As seen from FIG. 3-12, load variations should be confined within the stabilization region of SUPPLY #2 since there is an initial adjustment error ( $\Delta E_0$ ) between the two supplies.

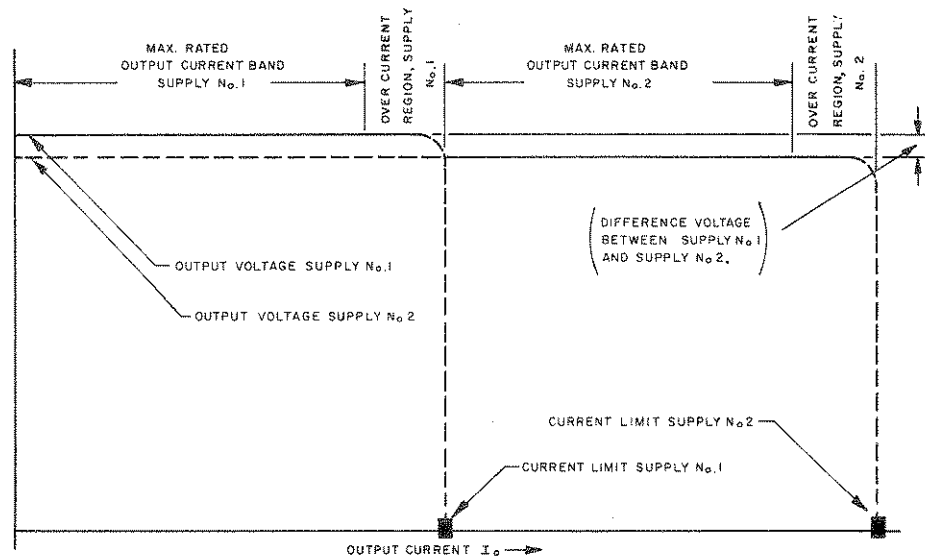

FIG. 3-12 "AUTOMATIC" PARALLEL OPERATION (TWO SUPPLIES).

3-45 **MASTER/SLAVE PARALLEL CONNECTION.** Two power supplies are shown in FIG. 3-14, although more can be paralleled, each unit requiring its own sampling resistor. The sampling resistors ( $R_{S1}$ ,  $R_{S2}$  in FIG. 3-14) are of equal value and are selected such that the voltage drop across them (due to the output current), plus the voltage drop in the load connection leads does never exceed 0.5 volts. If the voltage drop across the load connecting leads alone is at least 0.1 volt, the sensing resistors can be deleted since the leads provide the necessary sample voltage. For equal current sharing, however, the lead *length* and *diameter* should be the same for both power supplies. Output control is exercised from the "Master" supply.

3-46 PROCEDURE FOR "MASTER/SLAVE" PARALLEL OPERATION (See FIG. 3-14)

- 1) Connect the power supplies to be paralleled to a common a-c source (preferably with a common "on-off" power switch).
- 2) Make all load and sensing connections as shown in FIG. 3-14. The error sensing connections may be deleted if the minor voltage drop across the load wires (which subtracts from the available compliance voltage) can be tolerated.
- 3) With the *individual* a-c power switches of the two power supplies in the "on" position, turn the *common* a-c power switch "on." Observe output panel meters on both power supplies. Adjust output control on the "Master" supply, such that both supplies share the load current equally.

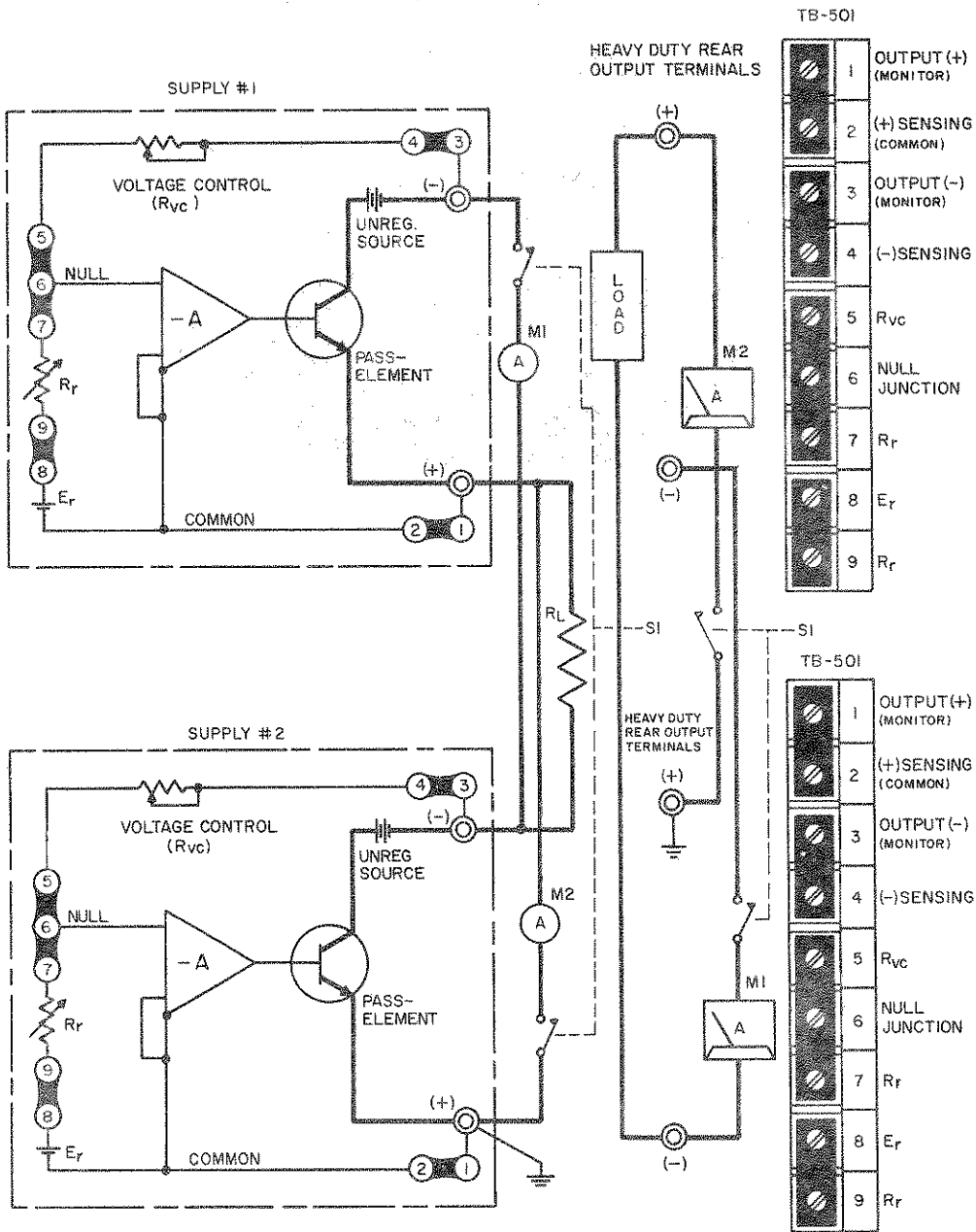

FIG. 3-13 BASIC PARALLEL CONNECTION OF TWO KEPKO POWER SUPPLIES

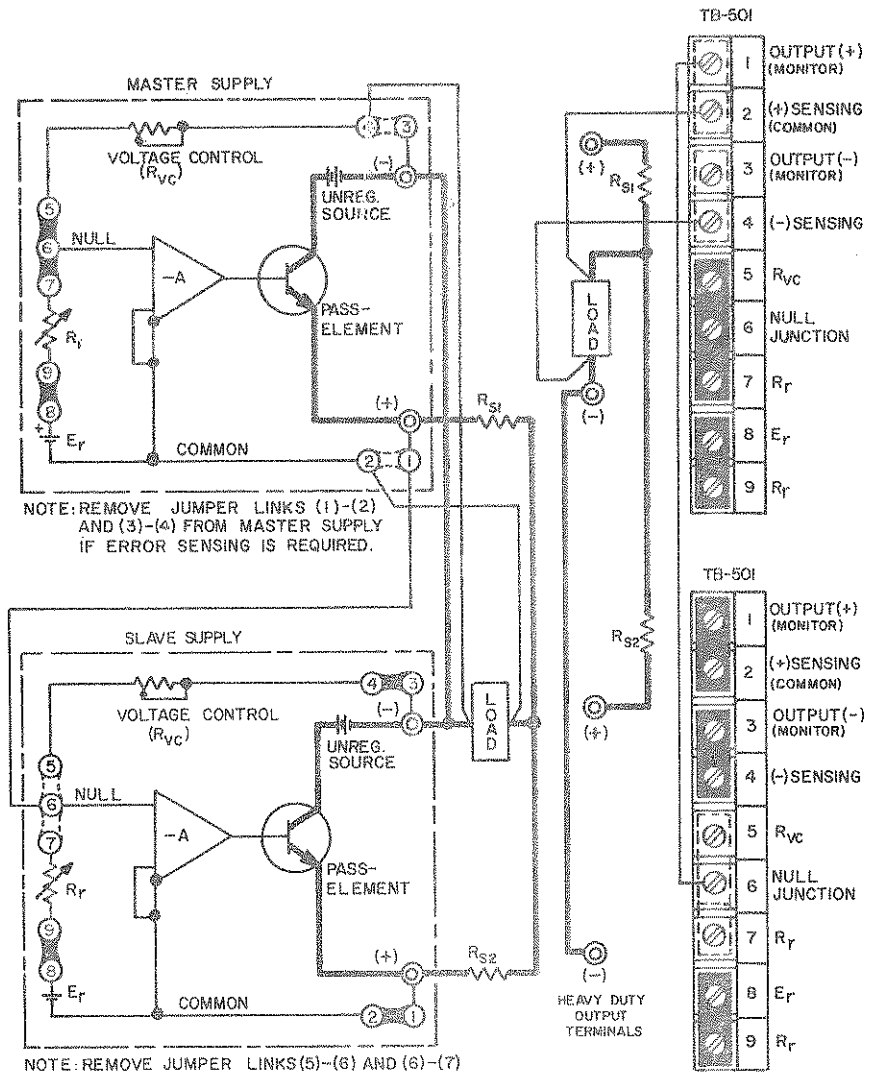

FIG. 3-14 MASTER SLAVE PARALLEL CONNECTION OF KEPKO POWER SUPPLIES





## SECTION IV – THEORY OF OPERATION

(References in CAPITAL LETTERS refer to the nomenclature used in FIG 4-1)

### 4-1 SIMPLIFIED DIAGRAM DISCUSSION (Refer to FIG 4-1)

- 4-2 The MAIN POWER TRANSFORMER converts the line voltage to the required levels needed to produce the DC operating voltages for the MAIN AND AUXILIARY SUPPLIES. The MAIN POWER SUPPLY is in series with the PASS-ELEMENTS and the CURRENT SENSING RESISTOR and produces the output voltage. The MAIN PASS-ELEMENTS are changing their series resistance in a way tending to keep the OUTPUT VOLTAGE constant. The necessary drive for this change is produced by the DRIVER CIRCUIT which in turn receives its command signals either from the CURRENT LIMIT AMPLIFIER or the ERROR SIGNAL AMPLIFIER.
- 4-3 The OUTPUT VOLTAGE is constantly compared to the REFERENCE SOURCE, while the output current is monitored by the CURRENT SENSING resistor. Any change, in either output voltage or current, is amplified by the associated amplifier and transferred to the GATE DIODES which feed directly into the DRIVER CIRCUIT and produce the needed drive signal for the MAIN PASS-ELEMENTS, thus either keeping the OUTPUT VOLTAGE constant, or if the signal from the CURRENT LIMIT AMPLIFIER is dominant, limiting the output current to the pre-adjusted value.
- 4-4 The OVERVOLTAGE PROTECTOR (Optional, on models with suffix "VP" only) is connected across the output terminals of the power supply. A portion of the output voltage is continuously compared to an internal reference. If an overvoltage occurs, the SCR "crowbar" will short-circuit the output immediately. Recycling takes place automatically, since the AC input power is removed by the tripping of the circuit breaker.

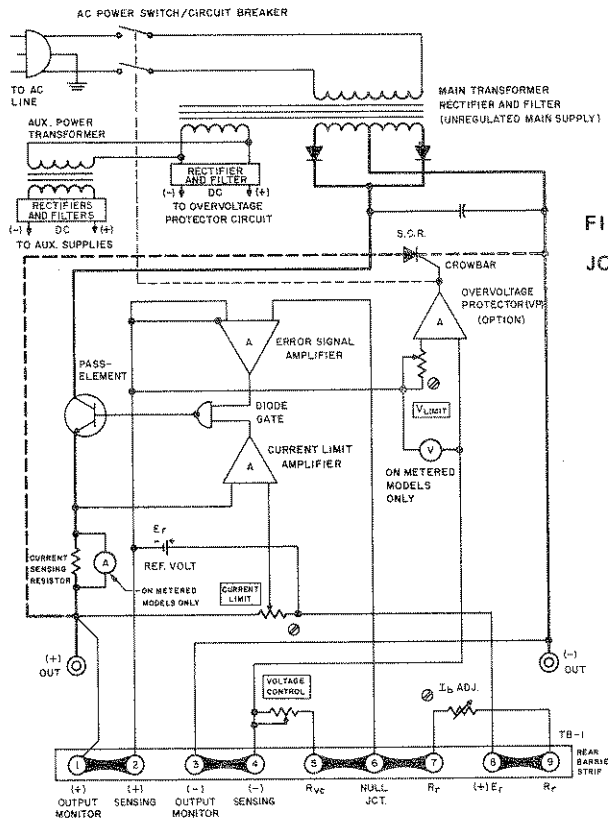

FIG. 4-1 SIMPLIFIED DIAGRAM,  
JOE FULL-RACK POWER SUPPLY

## 4-5 CIRCUIT DESCRIPTION

4-6 For the purpose of analysis, the circuitry of the JOE Power Supply may be divided into several sections which are individually described below. The main schematic (FIG. 6-3) should be used to illustrate the text of this section.

- a) **AC INPUT CIRCUIT.** AC line power is introduced through the AC input barrier-strip or a heavy duty three-wire line cord with safety plug.\* The use of a grounded AC power outlet will automatically ground the power supply, since the third wire of the line cord is directly connected to the metal chassis and case. Once the AC POWER SWITCH/CIRCUIT BREAKER (CB101) is closed, the primary of the main transformer (T201), the fans (B201,202) and the AC pilot light (DS101)\* will be energized. The two primary windings of the main transformer are either connected in parallel (for 115V AC nominal line voltage) or in series (for 230V AC nominal line voltage). The AC POWER SWITCH/CIRCUIT BREAKER (CB101), aside from switching the AC primary power, has the function of disconnecting the power supply from the AC line in case of overloads or short circuits. CB101 has two sensing coils, one of which is always in series with one of the primary windings on T201 (T2–T5), whether the main transformer is wired for 115V or for 230V AC. The second sensing coil of CB101 is in series with the secondary winding on T201 which generates the working potential for the overvoltage protection circuit (T201–T6,T7). If an overload occurs, due to either internal component failure or crowbar action of the voltage protector (models with suffix "VP" only), the coil is energized sufficiently to activate the trip-mechanism of CB101, thus disconnecting the power supply from the AC line. Since the primary coil of the AUXILIARY POWER TRANSFORMER (T202) is in parallel with the secondary for the overvoltage protection circuit, any failure in the auxiliary circuit, reflecting back to the primary of the auxiliary power transformer (T202) will also activate the sensing coil of CB101 and shut down the power supply. Thermal sensing elements (S301,S601) are mounted to HEATSINK ASSEMBLIES (A3,A6) to protect the series regulator transistors from over-temperature. If the pre-set temperature on S301 or S601 is exceeded, their contacts close and energize the sensing coil of CB101, resulting once more in the tripping of the AC POWER SWITCH/CIRCUIT BREAKER and subsequent removal of the AC input power from the power supply.
- b) **MAIN DC SUPPLY.** The main DC power is derived from a center-tapped secondary winding on T201. A full-wave rectifier circuit with silicon diodes (CR201,202) operates into a capacitor input filter (C201)\*\* which is paralleled by a bleeder resistor (R202). The main DC supply delivers the output current via the series regulator or pass-elements.
- c) **PASS-ELEMENT SECTION.** The pass-element section in the JOE Power Supply varies in complexity according to the output voltage and current rating of the particular model. The NPN silicon pass-transistors of the JOE are located on high-efficiency heatsinks and are cooled by fans (B201,B202). JOE models have dual heatsink assemblies (A3 and A6) with pass-transistors Q301 to Q3 . . . and Q601 to Q6 . . . , the number of transistors depending on the individual model. While in the low voltage/high output current models ( $E_o < 36$  volts) all pass-transistors are arranged in a parallel circuit, higher voltage models ( $E_o > 36$  volts) use a series/parallel configuration in the arrangement of their pass-transistors. In the latter, a "master/slave" circuit is used, where the "slave" section is sometimes paralleled by power resistors, which share in the power dissipation if the power supply is operating in the current-limit mode or under short-circuit conditions. However complex the pass-element section, for analytical purposes it can be reduced to a single pass-transistor. Electrically, this pass-transistor is part of a series circuit consisting of the unregulated main DC power supply, the external load and the pass-transistor. The output voltage of the power supply is kept constant, regardless of variations in the unregulated supply, by changing the series resistance of the control element (the pass-transistor) in the described series circuit. The necessary base-drive for the pass-transistors to affect the change in series resistance is supplied by the "Darlington" connected driver stages. The main driver stages in turn receive their base signals from the pre-driver stage (Q2) of the error-signal amplifier.

\*Line cord and AC pilot light used with metered models (suffix "M") only. On unmetered models with AC input barrier-strip, terminal "G" must be returned to AC ground.

\*\*C201 may consist of several parallel capacitors, see "MAIN SCHEMATIC."

- d) ERROR SIGNAL AMPLIFIER ( $A_V$ ). The main function of this DC amplifier is to amplify the error signal, derived from the comparison bridge, to level suitable to pass the diode gate circuit and drive the pre-driver stage (Q2). The error signal amplifier in the JOE Power Supply is a DC coupled, high gain operational amplifier in a plug-in package. The amplifier input may be disconnected from the comparison bridge circuit, and programmed externally. Although the plug-in amplifier is used in the non-inverting configuration, a positive input signal will produce a negative power supply output with respect to the "common" (plus (+) sensing terminal), since the pass-elements provide another signal inversion.
- e) COMPARISON BRIDGE. This four-arm electrical bridge circuit is the sensing and controlling element in the JOE Power Supply. The reference-half of the bridge consists of the reference resistors in series with the zener reference voltage ( $R_r = R4, R8$ ;  $E_r = CR3$ ), the other half is constituted by the voltage control resistor ( $R_{VC} = R102$ ) and the output voltage ( $E_O$ ). The simplified presentation shown in Section III of this manual will illustrate this discussion and show the actual bridge configuration. (Refer to FIG 3-3). The output voltage (in series with  $R_{VC}$ ) is continuously compared with the reference half of the bridge circuit. At bridge balance ( $E_{AA'} = 0$ , a constant bridge current ( $I_b$ ) is flowing through the bridge, keeping the error signal at the bridge terminals ( $A, A'$ ) at approximately zero volts. Any deviation in the output voltage ( $E_O$ ), caused either by line/load variation or by a change in  $R_{VC}$  will tend to change the bridge current ( $I_b$ ) in the sensing half of the bridge and thereby produce an error signal at the bridge terminals ( $A, A'$ ). The error signal is presented to the amplifier input and will after amplification, act as a drive for the pass-transistors, changing the voltage drop ( $E_p$ ) across them in such a way as to restore bridge balance and keep the output voltage ( $E_O$ ) constant once more.
- f) CURRENT LIMIT CIRCUIT. The differential input of the current limit amplifier (Q4,Q5) is connected to the current sensing resistor ( $R_s = R203$ )\* and to a reference voltage, adjustable by the current limit control (R101). The voltage drop across the current sensing resistor is thus continuously compared to the reference voltage, set by the current limit control. As long as the voltage developed across  $R_s$  (due to load current flow) is less than the pre-set voltage reference level, the current limit amplifier will be biased to its inactive state and will not effect the output. If the output current increases however, the voltage drop across  $R_s$  will overcome the reference level set by the current limit control. The current limit amplifier will be thus activated and produce a drive signal at the diode gate, greater than  $A_V$ , thereby taking control away from the error signal amplifier and transferring the power supply into the current limit mode. Since both, the current limit amplifier and the error signal amplifier ( $A_V$ ) are coupled through the diode gate circuit (CR14,15) to the pre-driver stage (Q2), the amplifier with the greater (negative) output will control the pass-transistors and therefore the output.
- g) OVERVOLTAGE PROTECTION CIRCUIT (A4, contained in Models with suffix—"VP").
- 1) Input and output connections for the overvoltage protection circuit (VP) are made via a single printed circuit board connector (P401) and its associated mating plug. The VP contains its own auxiliary power supply with only the AC voltage derived from a secondary of the main transformer (T202) and introduced via P401/J207. The AC is rectified by a conventional bridge rectifier (CR401), capacitor filtered by the input filter capacitor (C401) and shunt regulated by a zener diode (CR405). A six volt source is derived from the pre-regulated DC voltage by means of another zener diode (CR406) thus providing a stable reference source ( $E_{ref}$ ).
  - 2) The overvoltage protection circuit contains a dual input Schmitt-Trigger (Q402,403) in a voltage comparison configuration. A fixed part of the reference voltage ( $E_{ref}$ ) is applied to the "reference input" (Base of Q402), and a portion of the power supply output voltage ( $E_O$ ) to the "sensing input" (Base of Q403), so that the ratio  $E_O/E_{ref}$  is continuously sampled. Adjustment of the "Voltage Limit" controls (R414,R415), connected as a part of the voltage divider on the "sensing input" keeps the ratio  $E_O/E_{ref}$  constant, as the power supply output voltage is varied throughout the specified range (3V to  $E_O$  max. rated). The inputs to the Schmitt-Trigger are thus balance and the circuit is inactive.
  - 3) In the event of an overvoltage, resulting either from external causes or from internal power supply failure, the circuit becomes active. Since the "reference input" of the Schmitt-Trigger is rigidly clamped to a fixed reference, a positive input at the "sensing input" (due for example to an overvoltage) will result in a change of state in Q402, producing an output pulse. The output pulse from the Schmitt-Trigger stage, transferred via the emitter follower (Q401) is applied to the

\*In models with  $I_O$  max. > 50A DC, the base of Q4 is fed from the meter-amplifier ( $A_{V1}$ ). Refer to par. 4-6i for details.

first SCR (CR402). The changing time constant at the output of the Schmitt-Trigger stage is determined by the value of the (adjustable) delay capacitor C403). In effect, the setting of C403 determines the "sensitivity" to overvoltage of the protection circuit. Minimum capacity will yield faster response but will also make the circuit more sensitive to spurious triggering. The control is factory set for fastest response consistent with stable operation under all conditions.

- 4) As the first SCR (CR402) is conducting due to the pulse from the Schmitt-Trigger, it performs two functions: It shorts out the DC supply for the voltage protection circuit, thereby creating an over current in one of the circuit breaker coils. Simultaneously, CR402 generates a firing pulse for the main SCR (CR203), which through its "crowbar" action short-circuits the power supply output. The AC POWER SWITCH/CIRCUIT BREAKER (CB101) trips due to the action of the first SCR (CR402), disconnecting the power supply from the power line. The protection circuit is automatically re-activated with the "turn-on" of the power supply via CB101.

h) AUXILIARY SUPPLIES

- 1) AMPLIFIER POWER SUPPLY. This full wave, bridge rectified source is derived from a secondary winding on the auxiliary transformer (T202). Rectified by CR8, the supply is capacitor filtered by C2. A current regulator stage (Q3), followed by a string of zener diodes (CR10-13), provides the operating voltage for the error signal amplifier ( $A_v$ ), the current limit amplifier stage (Q4,Q5) and the reference circuit (R4,R8,CR3).
- 2) PRE-DRIVER COLLECTOR SUPPLY. A half wave rectified (CR3) and capacitor filtered (C7) supply is derived from a secondary winding on T202. It delivers collector voltage to the pre-driver stage (Q2).
- 3) ICBO SUPPLY. This full-wave rectified auxiliary supply is derived from the winding of the auxiliary power transformer. Rectified by CR1 and filtered by C1, constant current is applied to the base of the pass-transistors (Via the constant current generator stage (Q1), thus insuring the necessary turn-off bias for these stages under all operating conditions, especially at elevated temperatures.

- i) METERING CIRCUIT (Models with suffix "M" only). Both, output voltage and output current are monitored by dual range front panel meters (M101,M102). The two meter ranges are 0 to 10% and 0 to 100% of the rated output voltage and output current and may be selected by meter range-switches (S101 for voltage, S102 for current), located between the front panel meters. While the output voltage is measured directly across the error sensing terminals (TB501-2,TB501-4), the output current is measured indirectly as a voltage-drop across the current sensing resistor (R203). On models with output current greater than 50A DC, a meter-amplifier ( $A_{v1}$ ) as connected between the resistor and the ammeter, to reduce the loading effect on the sensing resistor. On the models the offset control of the meter- amplifier (R26, See FIG. 2-1) is used to achieve perfect zero on the ammeter (M101). Adjustment of this control should be needed only in cases where either the meter amplifier or the ammeter must be replaced.

## SECTION V – MAINTENANCE

### 5-1 GENERAL

5-2 This section covers maintenance procedures, calibration and test measurements of the Kepco Model JQE Power Supplies. Conservative rating of components and the non-congested lay out should keep maintenance problems to a minimum. If trouble does develop however, the easily removed wrap-around cover and the plug-in feature of the circuit boards provide exceptional accessibility to all components of the supply.

### 5-3 DISASSEMBLY (Refer to FIG. 5-1)

- a) COVER REMOVAL. The wrap-around cover may be taken off by loosening and removing its (17) holding screws, as indicated.
- b) CIRCUIT BOARD REMOVAL. The printed circuit board is mounted with two (2) screws, which are removed from the side. After removal of the three printed circuit board connectors, the board may be lifted from its slide-guide.
- c) HEAT SINK REMOVAL. The heat sink assemblies are mounted with four (4) screws each to the chassis bottom. After the screws are taken out, the indicated wires may be removed and the assemblies lifted from the chassis.
- d) OVERVOLTAGE PROTECTOR (A4) REMOVAL. (On models with suffix—"VP" only). Remove the holding screw as indicated (Refer to FIG. 5-1) and lift assembly out.
- e) RE-ASSEMBLY. Re-assembly of all components takes place in reverse order of the above described procedures.

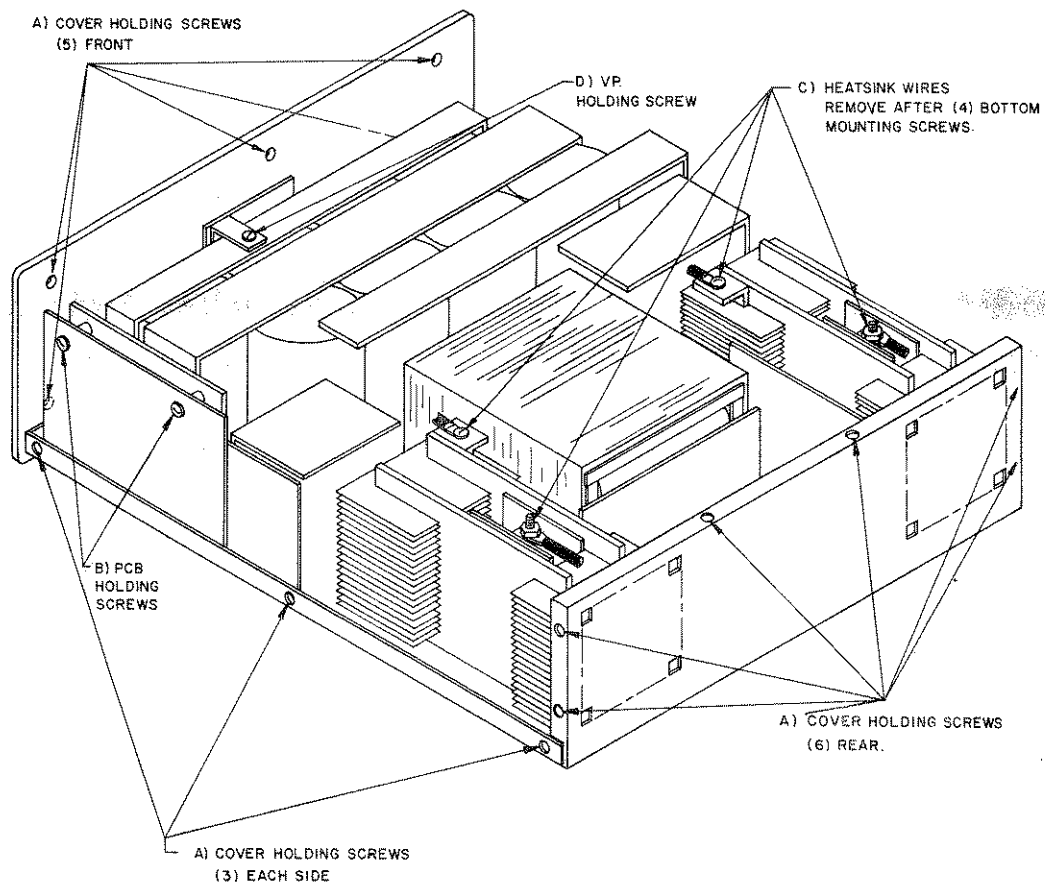

FIG. 5-1 DISASSEMBLY, JQE FULL-RACK MODELS

#### 5-4 INTERNAL ADJUSTMENT PROCEDURES

5-5 GENERAL. This paragraph describes all internal adjustment procedures, which have not been previously covered. Refer to Section II, paragraph 2-3 for a listing and location of all adjustment procedures.

5-6 MAXIMUM OUTPUT CURRENT ("I<sub>O</sub> max. adj.") ADJUSTMENT. This adjustment serves as a calibration for the range of the front panel Current Limit Control. The "I<sub>O</sub> max. adj." (R19) is located on the printed circuit board (Refer to FIG. 2-1). It is factory set so that the front panel control covers an output current range of 2–105% of the maximum rated output current. Re-adjustment of the "I<sub>O</sub> max. adj." control is to be restricted. A convenient way to make the adjustment is as follows:

- a) Load the output of the supply to draw the maximum desired output current with the front panel Current Limit Control fully clockwise. Monitor the output voltage with an oscilloscope, having a vertical sensitivity of at least 0.1 mV/cm.
- b) Observe the oscilloscope. Current limiting is indicated by a sharp increase in output ripple. Locate the "I<sub>O</sub> max. adj." control and turn slowly until limiting occurs at the point required. Clockwise adjustment will increase the maximum output current range, while counterclockwise adjustment will decrease the range. DO NOT ADJUST TO MORE THAN 105% I<sub>O</sub> max. Although this might be possible due to component tolerances, malfunction of the power supply will be caused by exceeding the rated maximum output current.

5-7 LAG NETWORK ADJUSTMENTS. With most models in the JQE series it is necessary to shape the gain-phase characteristics of the error-signal amplifier with external compensation networks, to achieve stability for any amount of feedback. Since gain and phase shift differ from model to model, either one or two adjustable lag networks are provided. (R16–C9 and/or R36–C10, \* see main schematic, FIG. 6-3). Lag network readjustment is indicated if components affecting the AC characteristics of the amplifier must be replaced or if the load connected to the power supply contains excessive capacity or inductance, causing AC instability. AC instability is usually indicated by high frequency oscillation as observed with an oscilloscope across the power supply load. In such cases, the lag network should be adjusted so that stable operation is resumed. If in extreme cases adjustment of the lag network should not prove sufficient, twisted-load and error-sensing wires or decoupling capacity directly across the load may provide a solution to the problem.

\*C12 in Model JQE 6–90.

#### 5-8 TROUBLE SHOOTING

5-9 Modern, high performance power supplies have reached a state of sophistication that requires thorough understanding of the problems involved in repairing complex, solid-state circuitry. Servicing beyond simple parts replacements should consequently be attempted only by personnel thoroughly familiar with solid state component techniques and with experience in closed-loop circuitry.

5-10 Trouble shooting charts, showing resistance and voltage readings, are of very limited usefulness with feedback amplifiers and are not included here. Instead a detailed circuit description (Section IV), parts location diagrams, simplified functional schematics and a main schematic with all significant voltage readings is present.

5-11 The following basic steps in a case of power supply malfunctioning may also be found useful:

- a) If power supply does not function at all: Check all powerline connections and fuses and make certain, power supply is connected to the correct line voltage (it is normally delivered for 115V AC operation).
- b) No DC Output:
  - 1) Check rear barrier-strip jumper connection for correct placement and tight seat (Refer to FIG. 4-1).
  - 2) Check the correct placement and tight seat of all transistors on the amplifier board (Refer to the component location drawings and parts list in Section VI).
  - 3) Check reference voltage from terminal (2) to (8) on the rear barrier-strip. Correct reference potential is 6.2 nominal.
  - 4) Check amplifier supply voltage from the "0 V DC" buss. (Refer to Main Schematic, FIG. 6-3).
  - 5) Test amplifier transistors\* Q2, Q3, Q4.

- c) HIGH DC OUTPUT: If the output voltage is high and not controllable by the voltage control, identical steps as outlined above (par. 5-11b) are advisable. In addition, if the condition persists, check the following:
  - 1) Check the predriver transistor\* (Q1) as well as all pass-elements (Q301–3 . . . , and Q601–6 . . . ) the number of pass-elements depending on the individual model.
  - 2) Check the voltage control resistor (R102) for continuity. Monitor output with an oscilloscope and observe ripple waveform and amplitude. If high frequency oscillations are observed proceed as directed below. (Refer to par. 5-11g). High 60 Hz ripple is often due to failure in one of the rectifier circuits. Measure the operating voltages under the conditions specified in the main schematic (FIG. 6-3).
- d) If supply does not function in one of the remote programming modes, disconnect all external components and reconnect internal reference and the voltage control. The following paragraphs refer to the instrument as a power supply, rather than an amplifier in order to simplify test setups and measurements.
- e) If the power supply is basically functioning, but poor performance is evident, inspect the test setup to make certain the source of the trouble is not external.
- f) Excessive output variations in any of the operating modes are usually traceable to incorrectly connected loads or faulty measurement techniques. Perform measurements as described in Paragraph 5-13 and follow the connecting diagrams.
- g) Oscillation of the output voltage or output current is often due to a load with a large inductive component. Twisted load wires of sufficient diameter and held as short as practical, are often the solution to the problem, if lag network adjustment does not correct the trouble (Refer to par. 5-7).

5-12 KEPCO Field Engineering Offices or the KEPCO Repair Department will be available for consultation or direct help in difficult service or application problems.

### 5-13 POWER SUPPLY MEASUREMENTS

5-14 Measurement of the significant parameters of a power supply is a requirement for incoming inspection, periodic maintenance, or after component replacement. Since the measurements require special techniques to insure correct results, suggestions for their performance are given below:

- a) Required Instrumentation:
  - 1) Constant AC source voltage with provisions for "stepping" the voltage over a specified region (105–125V), a variable autotransformer is generally adequate, if it is rated to deliver the input current of the unit under test.
  - 2) Resistive load, variable, with ON/OFF and SHORTING SWITCH and capable of dissipating the full output power of the unit under test.
  - 3) DC voltage monitor, differential voltmeter, or power supply analyzer.
  - 4) Current sensing resistor, for measurements of output effects in the current mode, four-terminal device.
  - 5) AC ripple monitor, sensitivity better than 1 mV. Ballantine Model 302C, or Hewlett Packard Model 400H.
  - 6) Optional: Oscilloscope, vertical sensitivity better than 0.1 mV/cm.
- b) FIG. 5-3 shows the proper location of instrument leads when measuring output effects. The principle governing this method of measurement is simply: DO NOT MEASURE ANY VOLTAGE DROPS DUE TO LOAD CURRENT FLOW. This can only be avoided by measuring output effects either directly at the sensing leads or by the use of four-terminal network. The four-terminal network can be approximated by the method shown in FIG. 5-3d.

**\*NOTE:** If a transistor checker is not available, transistors may be checked for shorts by means of an ohmmeter. Check between emitter and collector and reverse polarity of the ohmmeter. One reading should be high, the other low, the ratio being about 1:4.



- c) Output effects due to source or load variations in the voltage mode are defined as the amount of output voltage change resulting from a specified change of AC input source voltage or from a change in load resistance. The output effects can be expressed as an absolute change  $\Delta E_O$  or as a percentage in reference to the total output voltage  $E_O$ :

$$\text{Output Effect} = \frac{\Delta E_O}{E_O} \times 100\%$$

- d) Output effects due to source or load variations in the current mode are defined as the amount of output current change resulting from a specified change in AC input source voltage or from a change in load resistance. The output effects can be expressed as an absolute change  $\Delta I_O$ , or as a percentage in reference to the total output current  $I_O$ :

$$\text{Output Effect} = \frac{\Delta I_O}{I_O} \times 100\%$$

- e) RMS ripple may be monitored on a true RMS reading instrument connected parallel to the regulation analyzer leads. Careful wire dressing and shielding, as well as good AC grounding are of the utmost importance if valid measurements are being expected. An oscilloscope may also be used for p-p readings of noise and ripple. An approximate RMS reading can be calculated from the p-p reading of the oscilloscope if the reading is divided by three.

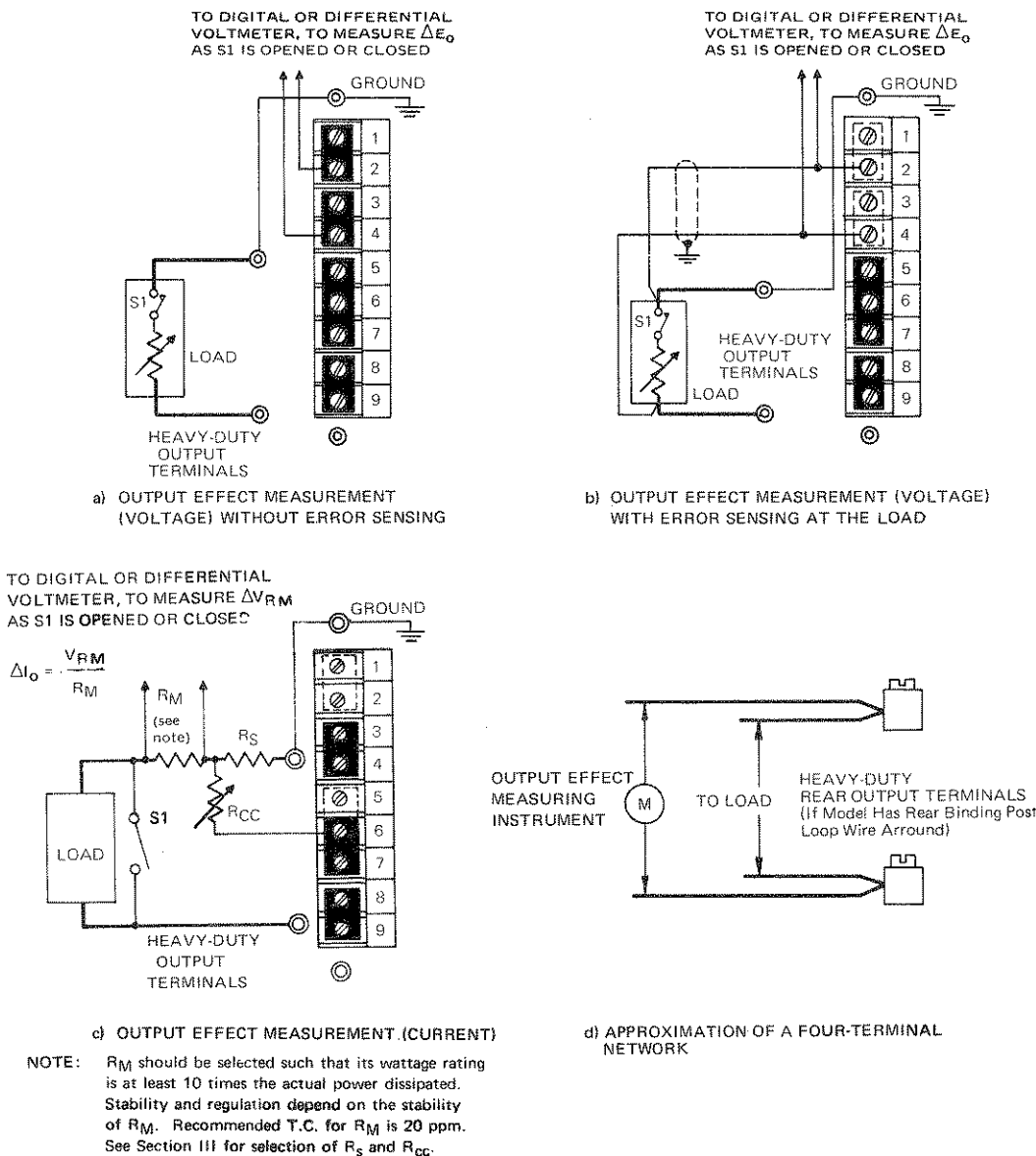

## SECTION VI – ELECTRICAL PARTS LIST AND DIAGRAMS

### 6-1 GENERAL

- 6-2 This section contains the main schematic, the parts location diagrams, and a list of all replaceable electrical parts. All components are listed in alpha-numerical order of their reference designations. Consult your Kepco Representative for replacement of parts not listed here.

### 6-3 ORDERING INFORMATION

- 6-4 To order a replacement part or to inquire about parts not listed in the parts list, address order or inquiry either to your authorized Kepco Sales Representative or to:

KEPCO, INC.  
131–38 Sanford Avenue  
Flushing, N.Y. 11352

- 6-5 Specify the following information for each part:

- a) Model and complete serial number of instrument.
- b) Kepco part number.
- c) Circuit reference designator.
- d) Description.

- 6-6 To order a part not listed in the parts list, give a complete description and include its function and location.

**NOTE: KEPCO DOES NOT STOCK OR SELL COMPLETE POWER SUPPLY SUBASSEMBLIES AS DESCRIBED HERE AND ELSEWHERE IN THIS INSTRUCTION MANUAL. SOME OF THE REASONS ARE LISTED BELOW:**

- 1) Replacement of a complete subassembly is a comparatively rare necessity.
- 2) Kepco's subassemblies are readily serviceable, since most of them are of the "plug-in" type.
- 3) All active components are socket mounted, making replacement extremely easy.
- 4) The nature of a closed-loop power supply system requires that subassembly replacement is followed by careful measurement of the total power supply performance. In addition, depending on the function of the subassembly, extensive alignment may be required to restore power supply performance to specified values.

**IF REPAIRS INVOLVING SUBASSEMBLY REPLACEMENTS ARE REQUIRED, PLEASE CONSULT YOUR LOCAL KEPCO REPRESENTATIVE OR THE KEPCO SALES ENGINEERING DEPARTMENT IN FLUSHING, NEW YORK, N.Y.**

## ABBREVIATIONS USED IN KEPKO PARTS LISTS

### A) Reference Designators:

A	= Assembly	L	= Inductor
B	= Blower (Fan)	LC	= Light-Coupled Device
C	= Capacitor	M	= Meter
CB	= Circuit Breaker	P	= Plug
CR	= Diode	Q	= Transistor
DS	= Device, Signaling (Lamp)	R	= Resistor
F	= Fuse	S	= Switch
FX	= Fuse Holder	T	= Transformer
IC	= Integrated Circuit	TB	= Terminal Block
J	= Jack	V	= Vacuum Tube
K	= Relay	X	= Socket

### B) Description Abbreviations

A	= Ampere	DC	= Direct Current
AC	= Alternating Current	DPDT	= Double Pole, Double Throw
AMP	= Amplifier	DPST	= Double Pole, Single Throw
AX	= Axial	ELECT	= Electrolytic
CAP.	= Capacitor	F	= Farad
CER	= Ceramic	FILM	= Polyester Film
CT	= Center-Tap	FLAM	= Flammable
°C	= Degree Centigrade	°F	= Degree Fahrenheit
FXD	= Fixed	RAD	= Radial
Ge	= Germanium	RECT	= Rectifier
H	= Henry	REG	= Regulated
Hz	= Hertz	RECY	= Recovery
IC	= Integrated Circuit	RES	= Resistor
K	= Kilo ( $10^3$ )	RMS	= Root Mean Square
m	= Milli ( $10^{-3}$ )	Si	= Silicone
M	= Mega	S-End	= Single Ended
MFR	= Manufacturer	SPDT	= Single Pole, Double Throw
MET.	= Metal	SPST	= Single Pole, Single Throw
n	= Nano ( $10^{-9}$ )	TAN	= Tantalum
NC	= Normally Closed	TSTR	= Transistor
NO	= Normally Open	u	= Micro (u) ( $10^{-6}$ )
P	= Pico ( $10^{-12}$ )	VAR	= Variable
PC	= Printed Circuit	V	= Volt
POT	= Potentiometer	W	= Watt
PIV	= Peak Inverse Voltage	W.W.	= Wire Wound
p-p	= Peak to Peak		
ppm	= Parts Per Million		
PWR	= Power		



# REPLACEMENT PARTS LIST

AMPLIFIER BOARD ASSEMBLY (A1), MODEL JQE 55-20(M) (T) (E)

Code 4-2870

SCHEMATIC NO.	QTY.	DESCRIPTION	MFRS. NAME & PART NO. (SEE NOTE)	KEPCO PART NO.
A <sub>v</sub>	1	Plug-In Amplifier	Kepeco 250-0013	250-0013
C1	1	Capacitor,Electrolytic,Pigtail 290 μF, 20V	Sangamo 052FE	117-0716
C2	1	Capacitor,Electrolytic,Pigtail 75 μF, 50V	Sprague 30D756G0050DF2	117-0646
C3,4	2	Capacitor,Electrolytic,Pigtail 150 μF, 3V	General Electric 7602BF151	117-0512
C5	1	Capacitor,Mylar,Pigtail 0.1 μF, 600V	TRW X663F	117-0316
C6,10	2	Capacitor,Mylar,Pigtail 1 μF, 200V	Wesco 33MM	117-0395
C7	1	Capacitor,Electrolytic,Pigtail 290 μF, 12V	Sprague 30D297G012DF2	117-0647
C8	1	Capacitor,Mylar,Pigtail 0.01 μF, 200V	Sprague 192P10302	117-0353
C9	1	Capacitor,Mylar,Pigtail 0.05 μF, 200V	Sprague 192P10302	117-0315
CR1,6,8	3	Rectifier,Silicon,Bridge,Pigtail	TRW X663F	124-0346
CR2,9, 10,12,13	5	Zener Diode	Transitron 1N763-1	121-0028
CR3*,11	2	Zener Diode	International Resistance 1N821	121-0041
**CR3	1	Zener Diode	International Resistance 1N827	121-0062
CR4,5	2	Rectifier,Silicon,Pigtail	EDI CEC 1000	124-0178
CR7,14,15	3	Rectifier,Silicon,Pigtail	Semtech SE-1	124-0133
CR16	1	Rectifier,Silicon,Pigtail	Semtech SE-4	124-0028
***CR17	1	Zener Diode	International Resistance 1N821	121-0041
Q1	1	Transistor,NPN	RCA 2N3441	119-0071
Q2,3	2	Transistor,NPN	M.S. Transistor 119-0094	119-0094

\*Deleted on models with suffix "T."

\*\*Models with suffix "T" only.

\*\*\*Models with suffix "E" only.

**NOTE:**

REPLACEMENT PARTS MAY BE ORDERED FROM KEPCO, INC. ORDERS SHOULD INCLUDE KEPCO PART NUMBER AND DESCRIPTION.

PLEASE NOTE: THE MANUFACTURER'S NAME AND PART NUMBER LISTED FOR EACH ITEM ON REPLACEMENT PARTS LISTS, REPRESENTS AT LEAST ONE SOURCE FOR THAT ITEM AND IS LISTED SOLELY FOR THE CONVENIENCE OF KEPCO EQUIPMENT OWNERS IN OBTAINING REPLACEMENT PARTS LOCALLY. WE RESERVE THE RIGHT TO USE EQUIVALENT ITEMS FROM ALTERNATE SOURCES. KEPCO, INC.





# REPLACEMENT PARTS LIST

AMPLIFIER BOARD ASSEMBLY (A1), MODEL JOE 55-20(M) (T) (E)

Code 4-2870

SCHMATIC NO.	QTY.	DESCRIPTION	MFRS. NAME & PART NO. (SEE NOTE)	KEPCO PART NO.
Q4,5	2	Transistor,NPN	Fairchild 2N5133	119-0093
R1	1	Resistor,Fixed,Molded 68 ohm, 1 W, 5%	Allen Bradley GB6805	115-2402
R2	1	Resistor,Fixed,Molded 1.5 K ohm, 1/2 W, 5%	Allen Bradley EB1525	115-0442
R3	1	Resistor,Fixed,Molded 560 ohm, 1/2 W, 5%	Allen Bradley EB5615	115-0888
R4	1	Resistor,Variable,WW 1 K ohm, 1/2 W, 10%	Amphenol Controls Division 2600P-102	115-2264
R5	1	Resistor,Fixed,Molded 560 ohm, 1/4 W, 5%	IRC GBT 1/4	115-2210
R6	1	Resistor,Fixed,Precision,M.F. 10 K ohm, 1/4 W, 1%	IRC CEA	115-2174
R7	1	Resistor,Fixed,Precision,M.F. 750 ohm, 1/4 W, 1%	IRC CEA	115-2259
R8	1	Resistor,Fixed,Precision,M.F. 5.7 K ohm, 1 W, 1%	Tepro TS-1W	115-1301
R9	1	Resistor,Fixed,Precision,M.F. 210 ohm, 1 W, 1%	Tepro TS-1W	115-1936
R10	1	Resistor,Fixed,M.G. 82 K ohm, 1/4 W, 5%	IRC RG 1/4	115-2012
R11	1	Resistor,Fixed,Molded 3.9 K ohm, 1/2 W, 5%	Allen Bradley EB3925	115-0808
R12,26	2	Resistor,Fixed,Molded 1 K ohm, 1/2 W, 5%	Allen Bradley EB1025	115-0340
*R13	1	Resistor,Fixed,M.G. 1.3 K ohm, 1/4 W, 5%	IRC RG 1/4	115-2379
**R14	1	Resistor,Variable,Trimpot,Cermet 100 K ohm, 3/4 W	Bourns 3009P-1-104	115-2399
*R15	1	Resistor,Fixed,Precision,M.F. 40.2 K ohm, 1/4 W, 1%	IRC CEA	115-2391
**R15	1	Resistor,Fixed,Precision,M.F. 10 K ohm, 1/4 W, 1%	IRC CEA	115-2174
R16	1	Resistor,Variable,Cermet 500 ohm, 3/4 W, 10%	Bourns 3009P-1-501	115-2398
R17	1	Resistor,Fixed,Molded 47 ohm, 1/4 W, 10%	IRC GBT 1/4	115-2273

\*Deleted on models with suffix "E."

\*\*Models with suffix "E" only.

**NOTE:**

REPLACEMENT PARTS MAY BE ORDERED FROM KEPCO, INC. ORDERS SHOULD INCLUDE KEPCO PART NUMBER AND DESCRIPTION.

PLEASE NOTE: THE MANUFACTURER'S NAME AND PART NUMBER LISTED FOR EACH ITEM ON REPLACEMENT PARTS LISTS, REPRESENTS AT LEAST ONE SOURCE FOR THAT ITEM AND IS LISTED SOLELY FOR THE CONVENIENCE OF KEPCO EQUIPMENT OWNERS IN OBTAINING REPLACEMENT PARTS LOCALLY. WE RESERVE THE RIGHT TO USE EQUIVALENT ITEMS FROM ALTERNATE SOURCES.	KEPCO, INC.
--	-------------





# REPLACEMENT PARTS LIST

AMPLIFIER BOARD ASSEMBLY (A1), MODEL JQE 55-20(M) (T) (E)

Code 4-2870

SCHMATIC NO.	QTY.	DESCRIPTION	MFRS. NAME & PART NO. (SEE NOTE)	KEPCO PART NO.
R18	1	Resistor,Fixed,Molded 47 K ohm, 1/4 W, 10%	IRC GBT 1/4	115-2237
R19	1	Resistor,Variable,Cermet 20 K ohm, 3/4 W, 10%	Bourns 3009P-203	115-2393
R20	1	Resistor,Fixed,M.G. 6.2 K ohm, 1/4 W, 5%	IRC RG 1/4	115-2258
R21	1	Resistor,Fixed,Molded 12 K ohm, 1/4 W, 10%	IRC GBT 1/4	115-2276
R23	1	Resistor,Fixed,Molded 27 ohm, 1/4 W, 10%	IRC GBT 1/4	115-2317
R24	1	Resistor,Fixed,Molded 12 K ohm, 1 W, 10%	Allen Bradley GB1231	115-0090
R25,27	2	Resistor,Fixed,Molded 10 ohm, 1/4 W, 10%	IRC GBT 1/4	115-2230
R28	1	Resistor,Fixed,Molded 1.2 K ohm, 1/2 W, 5%	Allen Bradley EB1225	115-1167
*R29	1	Resistor,Fixed,Precision,M.F. 750 ohm, 1/4 W, 1%	IRC CEA	115-2259
*R30,31	2	Resistor,Fixed,Precision,M.F. 43.2 K ohm, 1/4 W, 1%	IRC CEA	115-2380
R34	1	Resistor,Fixed,Precision,M.F. 210 ohm, 1/4 W, 1%	Tepro TS-1W	115-2177
R36	1	Resistor,Variable,Cermet 10 ohm, 3/4 W, 10%	Bourns 3009P-1-100	115-2397

\*Models with suffix "E" only.

**NOTE:**

REPLACEMENT PARTS MAY BE ORDERED FROM KEPCO, INC. ORDERS SHOULD INCLUDE KEPCO PART NUMBER AND DESCRIPTION.

PLEASE NOTE: THE MANUFACTURER'S NAME AND PART NUMBER LISTED FOR EACH ITEM ON REPLACEMENT PARTS LISTS, REPRESENTS AT LEAST ONE SOURCE FOR THAT ITEM AND IS LISTED SOLELY FOR THE CONVENIENCE OF KEPCO EQUIPMENT OWNERS IN OBTAINING REPLACEMENT PARTS LOCALLY. WE RESERVE THE RIGHT TO USE EQUIVALENT ITEMS FROM ALTERNATE SOURCES.	KEPCO, INC.
--	-------------







# REPLACEMENT PARTS LIST

MAIN CHASSIS AND FRONT PANEL ASSEMBLY (A2), MODEL JOE 55-20(M) (T) (E)

Code 4-2870

SCHEMATIC NO.	QTY.	DESCRIPTION	MFRS. NAME & PART NO. (SEE NOTE)	KEPCO PART NO.
---------------	------	-------------	-------------------------------------	----------------

**FRONT PANEL ASSEMBLY CONTAINS:**

CB101	1	Circuit Breaker	Heinemann JA2A6A3	127-0273
*DS101	1	Pilot Light Assembly	Industrial Devices Glo-Dot 2100	152-0087
*M101	1	Meter 0-20A d-c	Honeywell Model 504	135-0452
*M102	1	Meter 0-60V d-c	Honeywell Model 504	135-0408
R101	1	Resistor, Variable, Composition 2 K ohm, 1/2 W, 30%	C.T.S. VA-45	115-2268
R102	1	Resistor, Variable, WW 60 K ohm, 2 W, 5%	Bourns 3507S1-603	115-2181
*S102,103	2	Switch	Stackpole SS-72-1	127-0254

\*Metered models only.

B201,202	2	Motor	Howard Industries 23112	148-0027
C201,202,203, 204,205,206	6	Capacitor, Electrolytic, Can 5.2 K $\mu$ F, 100V	General Electric 86F100MI	117-0730
C207,208	2	Capacitor, Mylar, Pigtail 0.01 $\mu$ F, 200V	Sprague 192P10302	117-0353
C209	1	Capacitor, Electrolytic, Can 7.3 K $\mu$ F, 75V	General Electric 86F500 Series	117-0774
CR201,202	2	Rectifier, Silicon, Stud	International Rectifier 40HF20	124-0354
*CR203	1	Rectifier, Silicon, Controlled	International Rectifier 40RCS10	124-0358
CR204	1	Rectifier, Silicon, Pigtail	Semicon S-5A4	124-0348
L201	1	Choke	Kepco 100-1876	100-1876
R201	1	Resistor, Fixed, Power, Axial 7.5 ohm, 5 W, 5%	Tepro TS-5W	115-0982
R202	1	Resistor, Fixed, Power, Strip 1 K ohm, 10 W, 5%	Tepro TS-10W	115-0304
R203	1	Resistor, Fixed, Power, Shunt 0.025 ohm, 50 W, 1%	Tepro TMK-50W	115-2333
R204,205	2	Resistor, Fixed, Power, Ribbon 8.5 ohm, 750 W, 5%	Kepco Magnetics 115-2474	115-2474
T201	1	Transformer	Kepco Magnetics 100-1828	100-1828
T202	1	Transformer	Kepco Magnetics 100-1865	100-1865

\*Models with suffix "VP" only.

**NOTE:**

REPLACEMENT PARTS MAY BE ORDERED FROM KEPKO, INC. ORDERS SHOULD INCLUDE KEPKO PART NUMBER AND DESCRIPTION.

PLEASE NOTE: THE MANUFACTURER'S NAME AND PART NUMBER LISTED FOR EACH ITEM ON REPLACEMENT PARTS LISTS, REPRESENTS AT LEAST ONE SOURCE FOR THAT ITEM AND IS LISTED SOLELY FOR THE CONVENIENCE OF KEPKO EQUIPMENT OWNERS IN OBTAINING REPLACEMENT PARTS LOCALLY. WE RESERVE THE RIGHT TO USE EQUIVALENT ITEMS FROM ALTERNATE SOURCES. KEPKO, INC.





# REPLACEMENT PARTS LIST

PASS ELEMENT ASSEMBLY (A3), MODEL JOE 55-20(M) (T) (E)

Code 4-2870

SCHEMATIC NO.	QTY.	DESCRIPTION	MFRS. NAME & PART NO. (SEE NOTE)	KEPCO PART NO.
C301	1	Capacitor, Mylar, Pigtail 0.1 $\mu$ F, 200V	Sprague 192P10492	117-0363
CR301	1	Rectifier, Silicon, Pigtail	Semtech SE-1	124-0133
Q301,302,303, 304,305,306, 307,308,309	9	Transistor, NPN	RCA 2N3442	119-0070
Q310	1	Transistor, NPN	RCA 2N3441	119-0071
R301,302, 303,304,306, 307,308,309	8	Resistor, Fixed, Power, Axial 0.2 ohm, 3 W, 3%	Tepro TS-3C	115-0450
R305	1	Resistor, Fixed, Molded 47 ohm, 1/2 W, 5%	Allen Bradley EB4705	115-0980
R310	1	Resistor, Fixed, Molded 470 ohm, 1/2 W, 5%	Allen Bradley EB4715	115-0919
R311	1	Resistor, Fixed, Molded 1 K ohm, 1/2 W, 10%	Allen Bradley EB1021	115-0547
R312	1	Resistor, Fixed, Molded 10 ohm, 1/4 W, 10%	IRC GBT 1/4	115-2230
S301	1	Thermostat	Stemco 110486	127-0248

**NOTE:**

REPLACEMENT PARTS MAY BE ORDERED FROM KEPCO, INC. ORDERS SHOULD INCLUDE KEPCO PART NUMBER AND DESCRIPTION.

PLEASE NOTE: THE MANUFACTURER'S NAME AND PART NUMBER LISTED FOR EACH ITEM ON REPLACEMENT PARTS LISTS, REPRESENTS AT LEAST ONE SOURCE FOR THAT ITEM AND IS LISTED SOLELY FOR THE CONVENIENCE OF KEPCO EQUIPMENT OWNERS IN OBTAINING REPLACEMENT PARTS LOCALLY. WE RESERVE THE RIGHT TO USE EQUIVALENT ITEMS FROM ALTERNATE SOURCES. KEPCO, INC.





# REPLACEMENT PARTS LIST

\*VOLTAGE PROTECTOR ASSEMBLY (A4), MODEL JQE 55-20(M) (T) (E) (VP)

Code 4-2870

SCHMATIC NO.	QTY.	DESCRIPTION	MFRS. NAME & PART NO. (SEE NOTE)	KEPCO PART NO.
C401	1	Capacitor, Electrolytic, Pigtail 140 $\mu$ F, 40V	Sangamo 052FE141W040B	117-0706
C402	1	Capacitor, Mylar, Pigtail 0.05 $\mu$ F, 200V	TRW X663F	117-0315
C403	1	Capacitor, Variable 80-480 pF, 175V	Arco PC46	117-0637
C404	1	Capacitor, Mylar, Pigtail 0.0068 $\mu$ F, 200V	TRW X663F	117-0552
CR401	1	Rectifier, Silicon, Bridge, Pigtail	Varo VE-28	124-0346
CR402	1	Rectifier, Controlled, Silicon (SCR)	Motorola 2N4441	124-0349
CR403	1	Zener Diode	Transitron 1N746A	121-0060
CR404,406	2	Zener Diode	Transitron 1N763-1	121-0028
CR405	1	Zener Diode	Motorola 1N3024B	121-0057
O401,402,403	3	Transistor, NPN	General Electric 2N336A	119-0056
R401	1	Resistor, Fixed, Power, Axial 0.5 ohm, 3 W, 5%	Hardwick Hindle 9/166A-46-0.5	115-0504
R402	1	Resistor, Fixed, Molded 10 ohm, 1/4 W, 10%	IRC GBT 1/4	115-2230
R403	1	Resistor, Fixed, Molded 330 ohm, 2 W, 5%	Allen Bradley HB3305	115-0882
R404	1	Resistor, Fixed, Molded 100 ohm, 1/4 W, 10%	IRC GBT 1/4	115-2231
R405,408,413	3	Resistor, Fixed, Molded 1 K ohm, 1/4 W, 10%	IRC GBT 1/4	115-2238
R406	1	Resistor, Fixed, Precision, M.F. 1.1 K ohm, 1/4 W, 1%	IRC CEA	115-2176
R407	1	Resistor, Fixed, Precision, M.F. 6.04 K ohm, 1/4 W, 1%	IRC CEA	115-2175
R409	1	Resistor, Fixed, Precision, M.F. 3.92 K ohm, 1/4 W, 1%	IRC CEA	115-2179
R410	1	Resistor, Fixed, Precision, M.F. 1.5 K ohm, 1/4 W, 1%	IRC CEA	115-2178
R411	1	Resistor, Fixed, Precision, M.F. 210 ohm, 1/4 W, 1%	IRC CEA	115-2177
R412	1	Resistor, Fixed, Precision, M.F. 10 K ohm, 1/4 W, 1%	IRC CEA	115-2174
R414	1	Resistor, Variable, Trimpot, WW 20 K ohm, 1/2 W	Amphenol Controls Division 2600P-203	115-2267
R415	1	Resistor, Variable, Cermet 1 megohm, 1/2 W, 10%	Bourns 3009P-1-202	115-2404

\*Not used in models with suffix "HS" (High Speed).

**NOTE:**

REPLACEMENT PARTS MAY BE ORDERED FROM KEPCO, INC. ORDERS SHOULD INCLUDE KEPCO PART NUMBER AND DESCRIPTION.

PLEASE NOTE: THE MANUFACTURER'S NAME AND PART NUMBER LISTED FOR EACH ITEM ON REPLACEMENT PARTS LISTS, REPRESENTS AT LEAST ONE SOURCE FOR THAT ITEM AND IS LISTED SOLELY FOR THE CONVENIENCE OF KEPCO EQUIPMENT OWNERS IN OBTAINING REPLACEMENT PARTS LOCALLY. WE RESERVE THE RIGHT TO USE EQUIVALENT ITEMS FROM ALTERNATE SOURCES. KEPCO, INC.



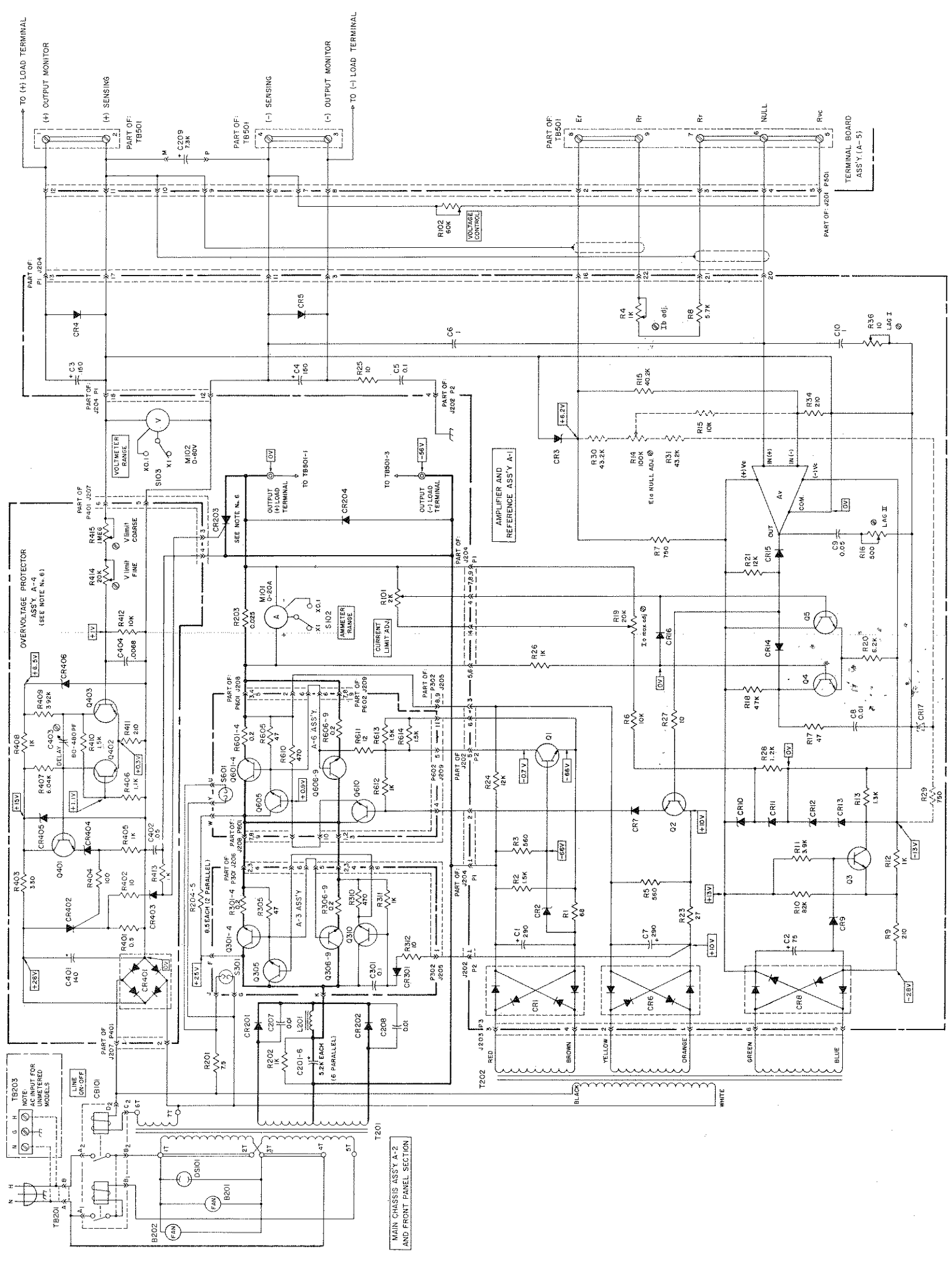

- NOTES:
1. RESISTOR VALUES IN OHMS, K=1000
  2. CAPACITOR VALUES IN MICROFARADS, UNLESS OTHERWISE INDICATED
  3. ALL TRANSISTORS ARE IN THE "COMMON EMITTER" CONFIGURATION UNLESS OTHERWISE SPECIFIED
  4. CONNECTORS SUFFIXED "T" ARE TRANSFORMER TERMINALS
  5. VOLTAGE READINGS TAKEN UNDER THE FOLLOWING CONDITIONS:
    - A) LINE AT 115 VAC, E<sub>o</sub> = MAX. RATED, I<sub>o</sub> = 0
    - B) METER, 20K OHM/VOLTAGE TO THE POSITIVE (+) SENSING TERMINAL, EXCEPT IN THE OVERVOLTAGE PROTECTOR CIRCUIT, WHERE THE VOLTAGE IS WITH RESPECT TO THE NEGATIVE (-) SENSING TERMINAL
    - C) METER, 20K OHM/VOLTAGE TO THE POSITIVE (+) SENSING TERMINAL, EXCEPT IN THE OVERVOLTAGE PROTECTOR CIRCUIT, WHERE THE VOLTAGE IS WITH RESPECT TO THE NEGATIVE (-) SENSING TERMINAL
  6. THE OVERVOLTAGE PROTECTOR (A-4) WITH COMPONENT NUMBERS 400-499 AND CR203 IS AN OPTIONAL ASSY, AND IS USED IN MODELS WITH SUFFIX "VP" ONLY.
  7. RED LINES ARE USED IN MODELS WITH SUFFIX "E" ONLY, R13(1.3K) AND R15(40.2K) ARE DELETED IN THESE MODELS.

- TB501
- |   |                    |
|---|--------------------|
| 1 | (+) OUTPUT MONITOR |
| 2 | (-) OUTPUT MONITOR |
| 3 | (+) SENSING        |
| 4 | (-) SENSING        |
| 5 | NULL JUNCTION      |
| 6 | NULL               |
| 7 | R <sub>1</sub>     |
| 8 | R <sub>2</sub>     |
| 9 | R <sub>3</sub>     |

FIG. 6-3 MAIN SCHEMATIC, MODEL JOE 55-20(M)



Data subject to change without notice  
 PATENT NOTICE: Applicable Patent Nos.  
 will be supplied on request.







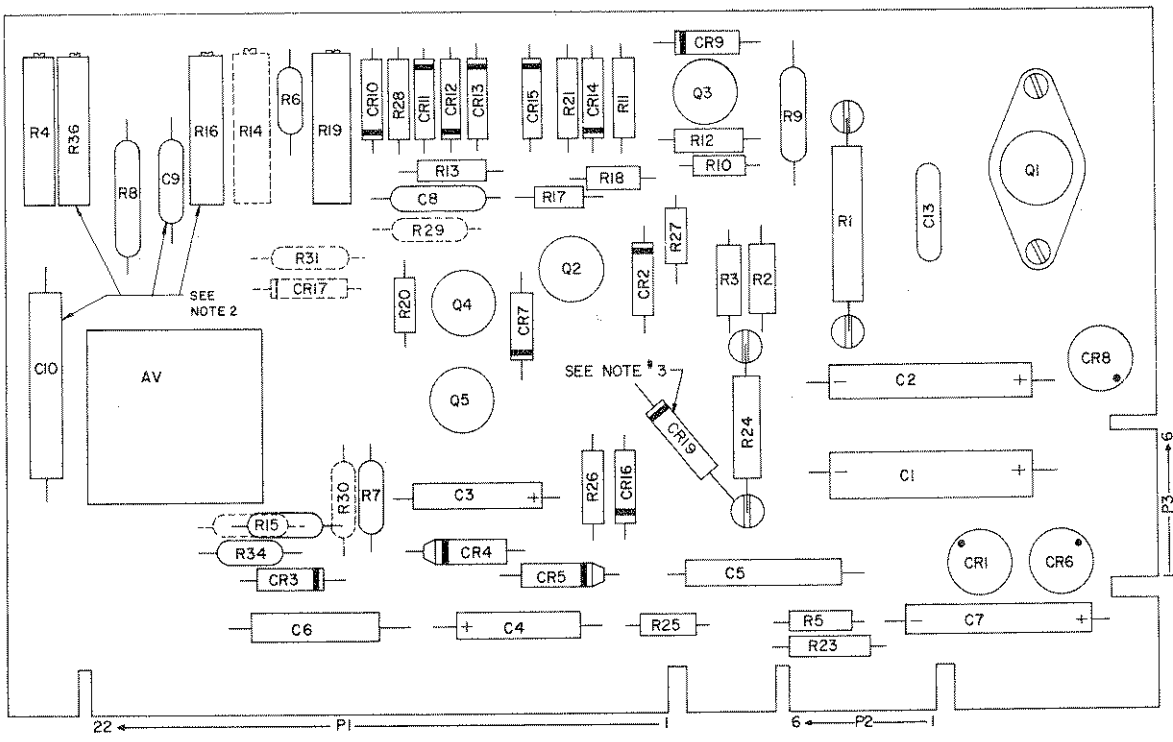

- NOTES:
1. COMPONENTS SHOWN IN DASHED LINES ARE FOR MODELS WITH SUFFIX "E" ONLY, AND R13 IS NOT USED IN THESE MODELS.
  2. LAG ADJ I (R36,C10) AND LAG II (R16, C9,C13) NOT ON ALL MODELS, SEE MAIN SCHEMATIC.
  3. CR19 NOT USED ON ALL MODEL, SEE MAIN SCHEMATIC.

a) AMPLIFIER (A1) ASS'Y

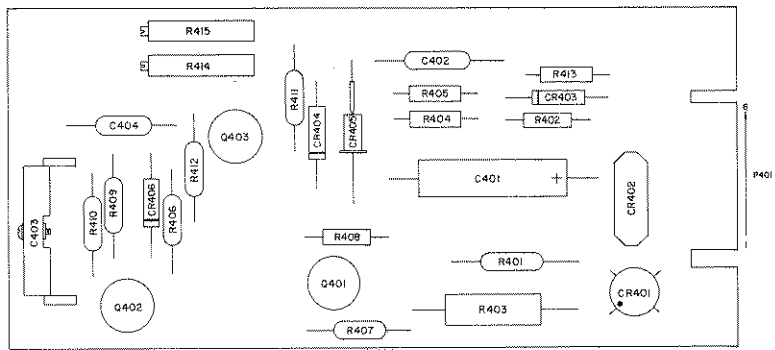

b) VOLTAGE PROTECTOR (A4) ASS'Y

FIG. 6-2 COMPONENT LOCATION, AMPLIFIER AND VP ASSEMBLY